

# CROWN AND BRIDGE RESTORATIONS WITH THE CAMLOG® IMPLANT SYSTEM



Basic Information  
Planning of the Prosthetic Restoration  
Fabrication of the Plaster Model  
Temporary Restorations  
Esthomic® Line of Abutments  
Universal Abutment  
Gold-Plastic Abutment  
Titanium Base CAD/CAM  
Ceramic Abutment

# TABLE OF CONTENTS

<b>GENERAL SYSTEM INFORMATION ON THE CAMLOG® IMPLANT SYSTEM</b>	<b>4</b>
<b>SYSTEM INTRODUCTION</b>	<b>5</b>
GENERAL GUIDELINES FOR THE FABRICATION OF IMPLANT-SUPPORTED PROSTHETICS	5
CAMLOG® TUBE-IN-TUBE™ IMPLANT ABUTMENT CONNECTION	6
NEW CAMLOG® ABUTMENTS WITH K ARTICLE NUMBER (K SERIES)	7
NEW CAMLOG® PS ABUTMENTS FOR PLATFORM SWITCHING (K SERIES)	8
CAMLOG COLOR-CODING	9
<b>PLANNING OF THE PROSTHETIC RESTORATION</b>	<b>10</b>
INTRODUCTION	10
DIMENSION CONTROL, WAX-UP/SET-UP	10
SILICONE INDEX	11
JAW RELATIONS	11
DIAGNOSTIC CASTS	11
PLANNING TEMPLATE	11
X-RAY/DRILLING TEMPLATES WITH TUBES FOR CT PLANNING	12
ABUTMENT SELECTION	13
RECOMMENDED INDICATIONS FOR THE CAMLOG® ABUTMENT TYPES	14
<b>CAST FABRICATION</b>	<b>15</b>
STANDARDIZED IMPRESSION AND CAST FABRICATION	15
IMPRESSION POSTS AND IMPRESSION POSTS PS FOR PLATFORM SWITCHING	15
CLOSED TRAY	17
OPEN TRAY	19
ACCESSORIES, PLASTER REAMER FOR CAST CONDITIONING	20
<b>TEMPORARY RESTORATIONS</b>	<b>21</b>
PRODUCT DESCRIPTION	21
TEMPORARY ABUTMENT	21
TEMPORARY ABUTMENT PS FOR PLATFORM SWITCHING	21
FABRICATION OF A TEMPORARY RESTORATION	22
<b>ESTHOMIC® LINE OF ABUTMENTS</b>	<b>24</b>
PRODUCT DESCRIPTION	24
ESTHOMIC® ABUTMENTS	24
ESTHOMIC® ABUTMENT, INSET	26
ESTHOMIC® ABUTMENTS PS FOR PLATFORM SWITCHING	27
ESTHOMIC® SELECTION ABUTMENTS	28
PROCESSING OF THE ESTHOMIC® ABUTMENTS	30
INDIVIDUAL PROCESSING/PREPARATION (EXAMPLE: CEMENTED SINGLE CROWN)	30
FABRICATION OF A CEMENTABLE CROWN ON AN ESTHOMIC® ABUTMENT	32
INSERTING THE ESTHOMIC® ABUTMENT AND THE CEMENTABLE CROWN	33
INDIVIDUAL PROCESSING/PREPARATION (EXAMPLE: CEMENTED BRIDGE)	35

<b>UNIVERSAL ABUTMENT</b>	<b>38</b>
PRODUCT DESCRIPTION	38
UNIVERSAL ABUTMENT	38
UNIVERSAL ABUTMENT PS FOR PLATFORM SWITCHING	39
INDIVIDUAL PROCESSING/PREPARATION OF THE UNIVERSAL ABUTMENT	39
<b>GOLD-PLASTIC ABUTMENT</b>	<b>40</b>
PRODUCT DESCRIPTION	40
PROCESSING (EXAMPLE: ALL CERAMIC CROWN)	40
MODIFICATION OF THE SCREW CHANNEL	40
WAX-UP	41
EMBEDDING AND CASTING	42
INSTRUCTIONS FOR THE CAST-ON ALLOY	42
DEVESTMENT	42
CASTING QUALITY	43
TRIMMING AND VENEERING	43
<b>TITANIUM BASE CAD/CAM</b>	<b>44</b>
PRODUCT DESCRIPTION	44
TITANIUM BASE CAD/CAM, FOR THE FABRICATION OF INDIVIDUAL MESOSTRUCTURES USING CAD/CAM TECHNIQUES	44
PROCESSING	44
BONDING OF THE MESOSTRUCTURE WITH THE TITANIUM BASE CAD/CAM	45
<b>CERAMIC ABUTMENT</b>	<b>46</b>
PRODUCT DESCRIPTION	46
PROCESSING	47
DETERMINATION OF THE ABUTMENT FORM	47
PROCESSING THE ZIRCONIUM OXIDE SLEEVE	47
BONDING THE ZIRCONIUM OXIDE SLEEVE TO THE TITANIUM BASE	48
<b>ACCESSORIES AND PROSTHETIC INSTRUMENTS</b>	<b>50</b>
<b>MATERIALS</b>	<b>51</b>
<b>FURTHER DOCUMENTATION</b>	<b>54</b>

# GENERAL SYSTEM INFORMATION ON THE CAMLOG® IMPLANT SYSTEM

## THE CAMLOG® IMPLANT SYSTEM

The CAMLOG® Implant System is based on many years of clinical and laboratory experience and is a user-friendly, consistently prosthesis-oriented implant system.

All CAMLOG® products are continually updated to the latest technological standards. The CAMLOG® Implant System is being continuously developed and adapted by the CAMLOG research and development team in collaboration with clinics, universities and dental technicians and therefore stays abreast of the latest developments in technology.

The CAMLOG® Implant System is very well documented scientifically. Numerous studies addressing a number of parameters, e.g., implant surface, time of implantation and/or implant loading, primary stability, connection design or type of suprastructure, support this. The long-term results for the CAMLOG® Implant System are convincing.

## ATTENTION!

The descriptions that follow are not adequate to permit immediate use of the CAMLOG® Implant System. Instruction by an experienced operator in the management of the CAMLOG® Implant System is strongly recommended. CAMLOG® dental implants and abutments should be used only by dentists, physicians, surgeons and dental technicians trained in the system. Appropriate courses and training sessions are regularly offered by CAMLOG. Methodological errors in treatment can result in loss of the implant and significant loss of peri-implant bone.



# SYSTEM INTRODUCTION

## GENERAL GUIDELINES FOR THE MANUFACTURE OF IMPLANT-SUPPORTED PROSTHETICS

Modern implant prosthetics is now an established component of dentistry. The expectations and demands of patients are steadily increasing. Therefore, the ultimate goal of modern implant-supported treatment concepts is for full esthetic, functional, phonetic, and psychosocial rehabilitation. This applies equally to replacements of lost single incisors associated with trauma and the complex rehabilitation of periodontally compromised remaining teeth or the treatment of an edentulous heavily atrophied maxilla and mandible.

Increasingly higher demands for quality and specialization require a multidisciplinary team approach to combine the members acquired knowledge and experience. Modern implant-supported restorations need a high level of attention to detail and clinical experience. This is true equally for the restorative dentist, the surgeon, the dental technician, and the dental office support staff such as the nurse, hygienist, and chair assistant. The CAMLOG team concept takes all of these demands into consideration. The sequence of treatment procedures is structured, and specific procedures are clearly assigned to specific team members once the joint planning phase is complete.

The implant-supported prosthetic restoration should be designed as simple and as safe as possible in regards to planning and fabrication. The required number of implants, as well as their length and diameter are determined based on the restoration planned later and the available bony implant site. The pre-implantation planning should be oriented exclusively to prosthetic needs (backward planning).

The patient is the focus of the implantological restoration. The patients needs and desires must play a part in the fabrication of the prosthetic restoration. This also requires taking into account anatomical relationships and conditions. Natural teeth are attached elastically by the periodontium to the alveolar bone. However, implants are rigidly anchored to the alveolar bone by the ankylotic connection to the bone substance. Mastication forces placed on implant-borne crown and bridge restorations are transferred directly to the bone. For this reason, the mastication forces should be transferred by a possible physiological process in the form of a suitable occlusion design thus supporting the long-term success of the integrated implants.

This can be achieved in the posterior occlusal area with a surface area of approx. 1 mm<sup>2</sup> that allows lateral freedom of movement of approx. 1 mm in habitual intercuspation. This makes it possible for the cusps to glide smoothly between the retrusive contact position (centric occlusion) and the maximum intercuspal position called «freedom in centric». In conjunction with a premolarized forming, overloads can be avoided. Extreme cusp formations should be avoided due to dentition that is too strong and vertical mastication forces affect the implant/antagonist axis preferably physiologically. Guidance functions of crown restorations on individual implants can lead to lateral force affects that are too strong and should be avoided. Appropriate planning should occur (e.g. wax-up) in advance.

# SYSTEM INTRODUCTION

## CAMLOG® TUBE-IN-TUBE™ IMPLANT ABUTMENT CONNECTION

All CAMLOG® implants are equipped with the proven Tube-in-Tube™ Implant Abutment Connection and feature three symmetrically arranged grooves (width 0.5 or 0.7 mm, depth 1.2 mm).

CAMLOG® abutments include three cams underneath the implant shoulder support that correspond to the three grooves in the implant/lab analog.

When inserting the abutments, their tubular extension toward the apex affects the simple, easy and safe orientation in the longitudinal axis of the implant/lab analog before the three cams rest on the shoulder of the implant.

The abutment is rotated until tactile engagement of the cams in the grooves of the implant/lab analog. The abutment is then in the final position.

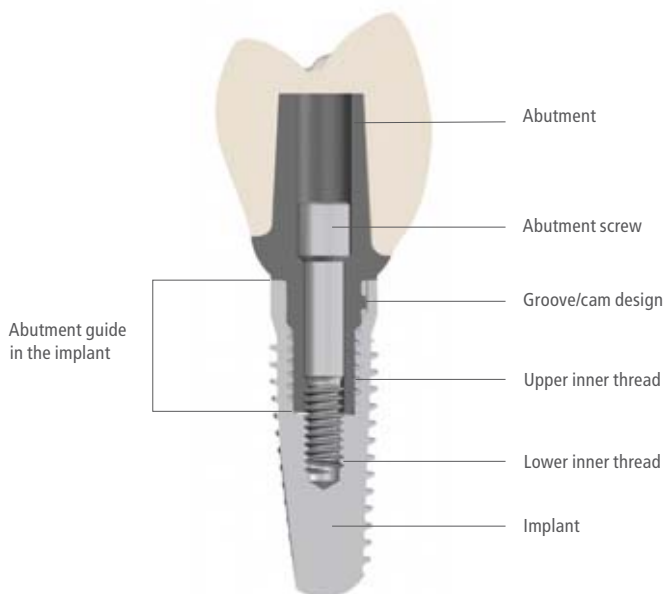

**NEW:** SCREW-LINE implants have square grooves (new inner configuration of the K-Series) in the cylindrical implant neck area.

New SCREW-LINE implants with K article numbers (K-Series) can only be fitted with abutments with K article numbers (K-Series).

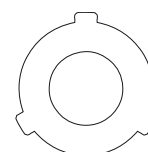
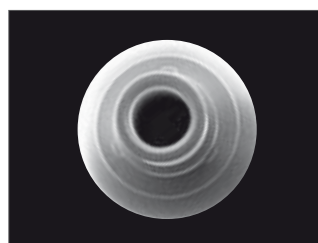
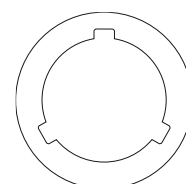
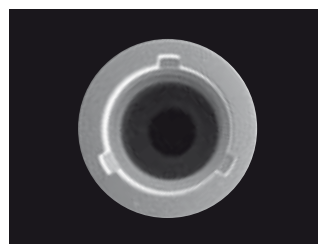

**WHAT DOES NOT WORK ...**

Due to the shortened grooves, the new SCREW-LINE implants with K article numbers (K-Series) can no longer be provided with conventional abutments and impression posts (long cams) with the J article number.

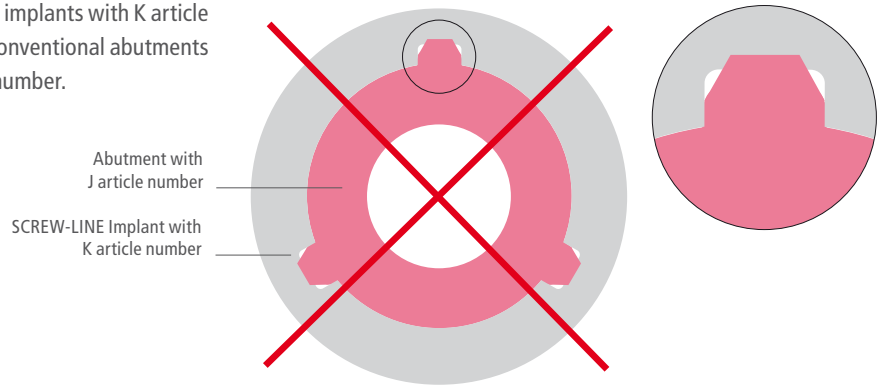

**EXISTING:** ROOT-LINE, SCREW-CYLINDER-LINE and CYLINDER-LINE implants feature the conventional grooves in the cylindrical implant neck area.

ROOT-LINE, SCREW-CYLINDER-LINE and CYLINDER-LINE implants can be provided with abutments of the K article numbers (K-Series) and abutments with J article numbers (backward compatibility).

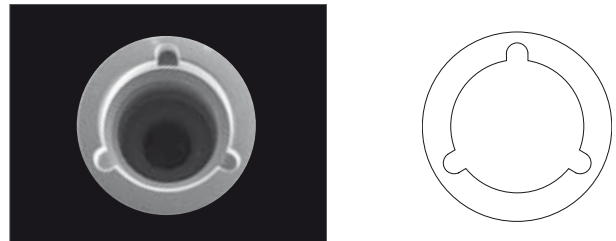

**NEW CAMLOG® ABUTMENTS WITH THE K ARTICLE NUMBER (K SERIES)**

As part of continued development of CAMLOG® products, all CAMLOG® abutments will be manufactured with shortened cams and be identified with K article numbers (K-Series). The abutments are adapted to the new SCREW-LINE implants with shortened cams (K-Series). The abutments of the K-Series are also compatible with the implants of the ROOT-LINE, SCREW-CYLINDER-LINE/CYLINDER-LINE.

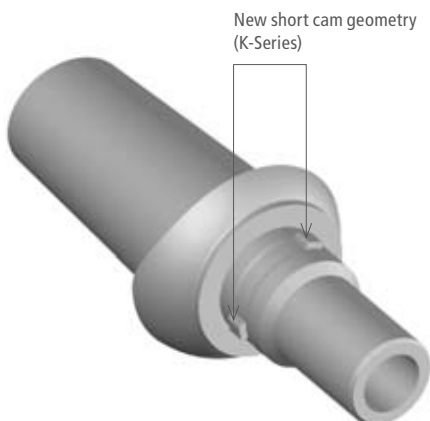
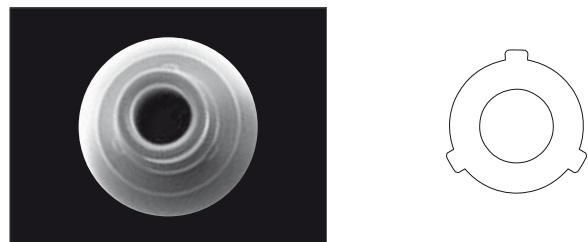

# SYSTEM INTRODUCTION

## NEW CAMLOG® ABUTMENTS PS FOR PLATFORM SWITCHING (K-SERIES)

The platform switching option is used to support the hard and soft tissue in esthetic areas. Because of the horizontal reduction of the diameter of the abutments PS in relationship to the implant diameter, the implant-abutment interface is transferred to the middle of the implant. This makes it possible to adapt soft tissue over the implant shoulder during the prosthetic restoration.

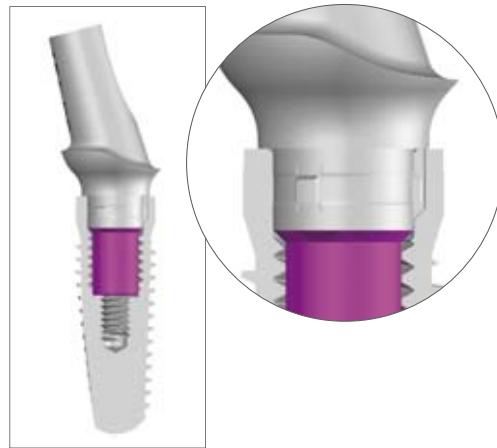
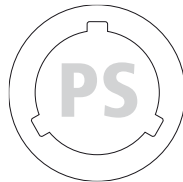

Abutment PS for platform switching in a SCREW-LINE implant of the K-Series

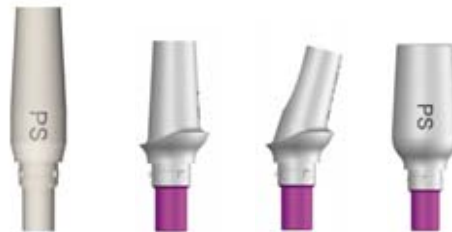

The option of platform switching is available with the Temporary abutment PS, the Esthomic® abutments PS and Universal abutments PS.

### IMPORTANT NOTE:

- All prosthetic components for platform switching have the PS label and K article number (K-Series).
- All prosthetic components PS for Platform Switching may only be used in conjunction with SCREW-LINE implants with K article numbers (K-Series).



## CAMLOG COLOR-CODING

To ensure that the correct lab analogs are used for the impression posts, the prosthetic components are color-coded to match the implant diameters.

You should make sure to match only lab analogs and prosthetic components of the same diameter (by color-coding). No components of different diameters should be attached to one another.

### COLOR-CODING OF THE SURGICAL AND PROSTHETIC CAMLOG® PRODUCTS

	COLOR	DIAMETER
	grey	3.3 mm
	yellow	3.8 mm
	red	4.3 mm
	blue	5.0 mm
	green	6.0 mm

# PLANNING OF THE PROSTHETIC RESTORATION

## INTRODUCTION

Modern implant prosthetics is planned by working back from the desired therapy goal; this is referred to as «backward planning.» It applies particularly to pre-implantation augmentation procedures to restore sufficient bony structure to allow placement of implants in the optimal prosthetic position.

Function, phonetics, and hygienic potential require prosthetically oriented implant positioning and dimensioning, which the dental technician defines on the basis of the wax-up/set-up. The prosthetic design and the required implant position(s) and axial alignment(s) are planned by the dentist and dental technician working closely together. This requires both to be fully informed of the treatment options.

If implant positions (implants approximating the former tooth positions) cannot be implemented for a fixed denture for whatever reason functional (implant loading, crown length), esthetic (soft tissue support) or hygienic a removable denture must be planned.

## DIMENSION CONTROL, WAX-UP/SET-UP

A silicone index is used to represent the space requirement for the planned restoration on the cast. The restoration is modelled directly without abutment in wax as a wax-up/set-up. The planned prosthetic result, the implant axis, the course of the gingiva, the alveolar ridge and the residual teeth are taken into account.



## SILICONE INDEX

The silicone index is then fabricated over the wax-up/set-up. The index should contain the tooth range from oral to vestibular. After curing, the index is divided along the incisal or occlusal midline. After removing the wax-up/set-up, the corresponding silicone index half (buccal or palatal/lingual half) shows the space requirement for the prosthetic restoration. After inserting the abutment into the cast, the necessary preparation for an optimal esthetic and function of the prosthetic reconstruction can be determined.



This process makes simple, fast dimension control for the prosthetic restoration options on CAMLOG® abutments possible and can be used further in the subsequent worksteps.

## ARCH RELATIONS

The arch relations has effects on the load direction and therefore on the axial alignment of the implants. This is particularly important with cross-bite situations. Crowns cannot be placed precisely over the implants in the presence of Angle Class II dentition because the soft tissues must be supported and the space for the tongue must not be reduced. A removable denture is indicated in this situation.

## DIAGNOSTIC CASTS

The diagnostic casts must clearly show not only the occlusal surfaces but also the vestibular fold and retromolar areas. The diagnostic casts are mounted in an adjustable articulator with the aid of an arbitrary face bow and centric registration as in perioprosthetics. If the occlusal height requires correction, this must be done with a splint therapy or long-term provisional before the implant-supported prosthetic restoration begins.

## PLANNING TEMPLATE

A planning template is fabricated to review the planned implant positions in the mouth. The template can be converted to a drilling template later. In this template, markers can be integrated as needed for radiological control of the planned implant positions.



# PLANNING OF THE PROSTHETIC RESTORATION

## X-RAY/DRILLING TEMPLATES WITH TUBES FOR CT PLANNING

In the planning template produced from the wax-up/set-up, CT-planning tubes are integrated at the ideal implantation position and are used as reference positions in the x-ray image. The tubes consist of two parts. The titanium used leaves no scattering on CT/DVT scans. The lower part is polymerized in the template and the upper part inserts into this. The complete tube is used in radiologic diagnostics, and the upper part can be removed during surgery. Titanium tubes for CT/DVT planning or other radio-opaque positioning components (e.g. steel, barium sulfate) are integrated, depending on the analysis software. If the tubes are placed directly on the mucous membrane, its thickness can be detected on the CT/DVT scan. For more information, see the documentation for these systems.

As an alternative to the drilling template with tubes for CT planning, a drilling template can be fabricated with the CAMLOG® Guide System that is used for template-guided preparation of the implant bed and for insertion of SCREW-LINE implants CAMLOG Guide. Further information is available in the «CAMLOG Guide System» work instruction.

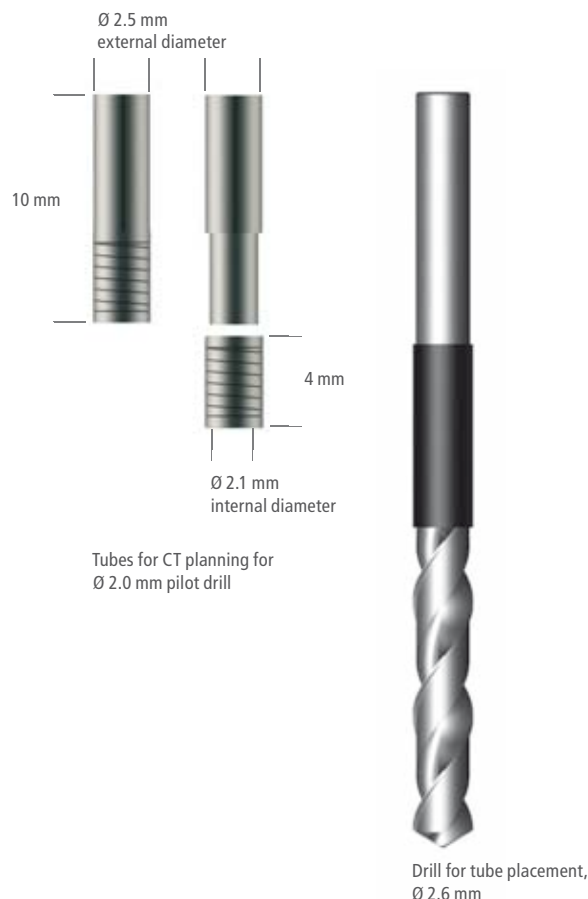

Planning template with tubes for CT/DVT planning



Template without tube upper section for use as a drilling template



X-ray template, reduced contact area with tubes



X-ray template with radio-opaque teeth, installed tubes and reference bodies for computer-based implant planning

## ABUTMENT SELECTION

In consideration of the previous prosthetic planning, abutments should be selected in collaboration with the dentist and dental technician. For Esthomic® abutments, selection abutments are available.

The previously prepared silicone index is used to specifically select the suitable abutment on the cast. The following information when making the selection is important: implant axis, implant length, gingival height, groove position (important for angled Esthomic® abutments) and the the vertical dimension of the implant to the occlusion level.

### IMPLANT AXIS

With a straight abutment, it is possible to correct implant axes of up to approx. 10° in axial alignment. If larger axis corrections are required, angled Esthomic® abutments or the gold-plastic abutment for creating an individual mesostructure must be selected.

### SELECTING THE GINGIVAL HEIGHT FOR ESTHOMIC® ABUTMENTS

As a selection criterion, the maximum mucosal thickness is the focus here. Because the final crown margin should lie vestibular 1.0–1.5 mm subgingivally, an Esthomic® abutment with appropriate gingival height must be selected. The crown margin can be prepared later for hygiene and esthetic reasons accordingly. To safely remove any remaining cement, the cement gap should not lie deeper than 1.5–2.0 mm subgingivally for cemented restorations.

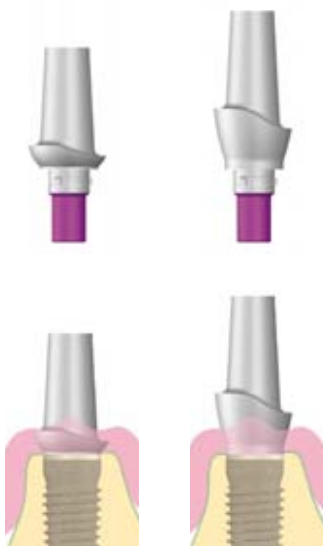

### VERTICAL DIMENSION TO THE THE OCCLUSION LEVEL

Information from implantologists for the length of implants used plays an important role in the prosthetic planning. Loading of the implant-bone interface is a result of the leverage relation generated by osseointegration-related resistance to the prosthesis load arm (equivalent to the supracrestal implant length plus the length of the crown above the implant shoulder). If IL is smaller than CL, then the load must be reduced (e.g. through prosthetic splinting). The ideal size ratio compared to the implant length for single-crown restorations is  $< 0.8$ .

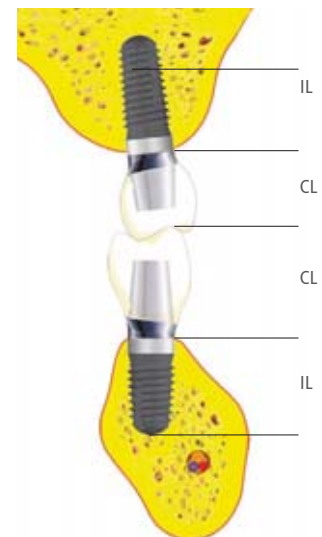

### NARROW SPACE

If the space is limited, the Esthomic® abutment, Inset is an appropriate solution. The distinctiveness of this abutment is that its maximum diameter is identical to the respective implant diameter.



# PLANNING OF THE PROSTHETIC RESTORATION

## RECOMMENDED INDICATIONS FOR THE CAMLOG® ABUTMENT TYPES

### TEMPORARY ABUTMENT

Temporary restorations with crown and bridge restorations in esthetically critical zones, also for platform switching



### ESTHOMIC® ABUTMENTS (STRAIGHT/ANGLED)

Cemented single crown and bridge restorations in esthetically critical zones, correction of implant axis divergences, also for platform switching



### UNIVERSAL ABUTMENT

Cemented single crown and bridge restorations, telescopic crown technique, also for platform switching



### GOLD-PLASTIC ABUTMENT

Cast-on technique, single crowns, individual implant pillars for cemented bridge restorations, telescopic crown technique



### TITANIUM BASE CAD/CAM

Individual CAD/CAM-fabricated mesostructures with zirconia ceramic for crown and bridge restorations in esthetically critical zones, telescopic crown technique



### CERAMIC ABUTMENT

Individual mesostructures for crown and bridge restorations in esthetically critical zones, direct ceramic veneering



# CAST FABRICATION

## STANDARDIZED IMPRESSION TAKING AND CAST FABRICATION

The impression is taken and the working cast manufactured with prefabricated components of the CAMLOG® Implant System. The CNC processing technique is used to fabricate all components. A precision rotation-resistant impression system for both closed and open impression methods is available. Simple standardized handling is available to the user and accurate transfer of the implant position to the cast is ensured. The impression is taken without abutment and directly from the implant shoulder.

## IMPRESSION POSTS AND IMPRESSION POSTS PS FOR PLATFORM SWITCHING

The impression can be taken with impression posts, open tray or impression posts, closed tray. Appropriate impression posts PS are available for the platform switching option. The impression posts include a special fixing screw.

**NOTE**

Impression taking of CAMLOG® implants and cast fabrication with the existing impression posts, open and closed tray, is identical to the impression posts PS, open and closed tray for platform switching.



Impression posts, open tray incl. fixing screw (3 mm may be shortened), PS for platform switching

Impression posts, closed tray incl. fixing screw, PS for platform switching

To fabricate the cast, a screwdriver (hex) and the lab analogs corresponding to the diameters are required in addition to the impression posts in the impression. A screwdriver (hex) is used to hand-tighten the impression post fixing screws with the lab analog for cast fabrication.

**IMPORTANT INSTRUMENTS**



Screwdriver, hex, extra short, short, long

**LAB ANALOGS**



Lab analog, diameters 3.3/3.8/4.3/5.0/6.0 mm

**IMPORTANT NOTE**

The impression posts and lab analogs may not be modified!

# CAST FABRICATION

## CAST FABRICATION FOR CAMLOG® ABUTMENT TYPES

The cast fabrication described subsequent is identical in all CAMLOG implant diameters for the following abutment types (incl. PS abutments for platform switching):



Temporary Abutment



Esthomic® abutments (straight/angled)



Universal Abutment



Gold-Plastic Abutment



Titanium Base CAD/CAM



Ceramic Abutment



## CLOSED TRAY

### PREPARATION

After the impression is taken, the impression cap remains in the impression.

In the dental laboratory the impression posts, closed tray, are connected with the corresponding lab analog (note proper seating).



Impression cap



Lab analog

Impression post,  
closed tray

Fixing screw

A screwdriver (hex) is used to hand-tighten the fixing screw.



The components repositioned in the impression caps. Make sure that the grooves correctly engage in the impression cap. Do not use bonding material!

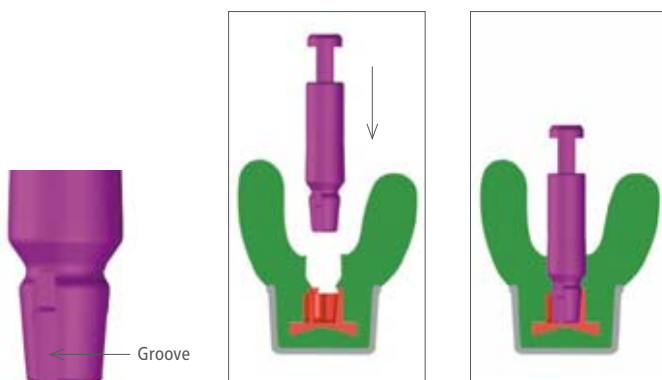

# CAST FABRICATION

## CAST FABRICATION

The impression is cast with appropriate cast plaster and the impression posts may not loosen. After curing, the impression is removed and the impression posts loosened from the lab analogs.

**TIP:** We recommend that you fabricate the cast with a gingival mask. The surrounding gingiva is represented elastically and true to the situation especially for subgingival crown margins and restorations in esthetic areas. An optimal design of the crown contour is easier to achieve.

**TIP:** After removing the impression, the bite registration caps can be installed on the impression posts in the plaster cast for mounting. After that, the bite registration can be placed on the caps and the casts mounted in the articulator.

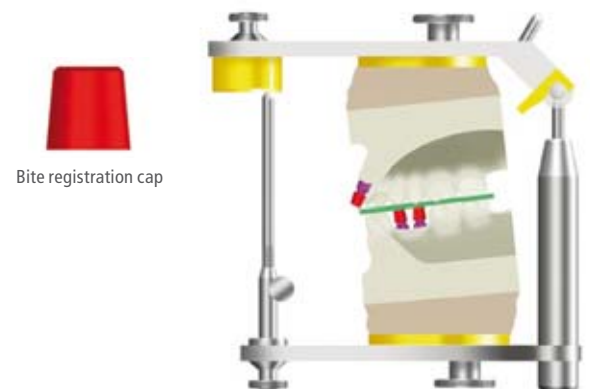
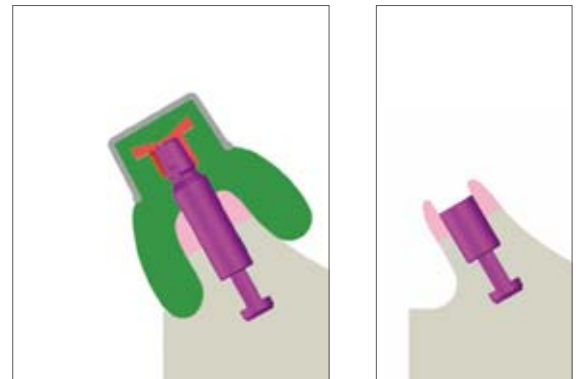

## NOTE

Cast fabrication and bite registration with the impression posts, closed tray, is identical to the impression posts PS, closed tray for Platform Switching.



**OPEN TRAY**

**PREPARATION**

After the impression is taken, the impression posts, open tray, are in the impression.

The lab analogs corresponding to the diameters are attached to the impression posts, open tray, in the impression (note proper seating). A screwdriver (hex) is used to hand-tighten the fixing screw.

**CAST FABRICATION**

The impression is cast with appropriate cast plaster. After curing, the impression posts are loosened from the lab analogs and the impression is removed.

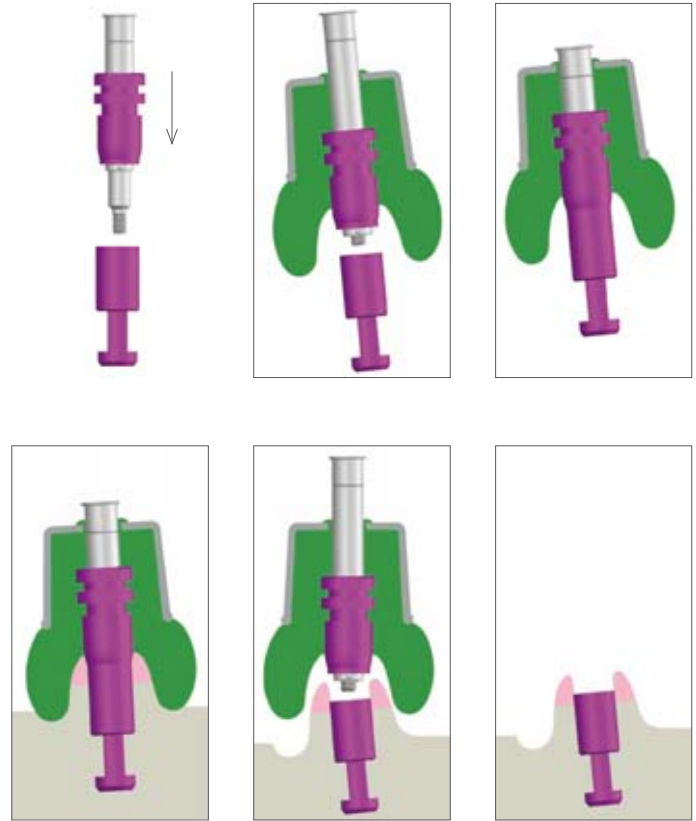

**TIP:** We recommend that you fabricate the cast with a gingival mask. The surrounding gingiva is represented elastically and true to the situation especially for subgingival crown margins and restorations in esthetic areas. An optimal design of the crown contour is easier to achieve.

**NOTE**

Cast fabrication with the impression posts, open tray, is identical to the impression posts PS, open tray for Platform Switching.



# CAST FABRICATION

## ACCESSORIES

### REAMER FOR CAST CONDITIONING

If no gingival mask was created during cast fabrication, the cervical implant neck area can be reworked with special plaster reamers. The milling profile exposes the lab analog shoulder to ensure the gapless seat of the abutment.

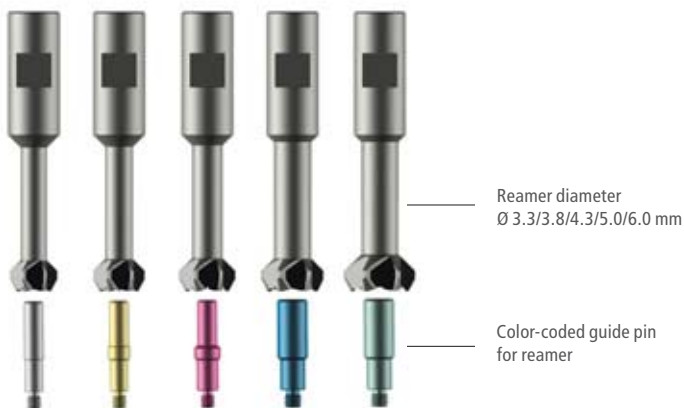

After fabricating the cast, the impression posts are removed. The abutment cannot be placed and plaster must be removed in the cervical area.



The reamer is inserted in the universal holder. After screwing in the guide pin, the reamer is moved over this and the plaster milled off in a clockwise rotation.



Once lowered completely, the reamer lies on the lab analog shoulder.

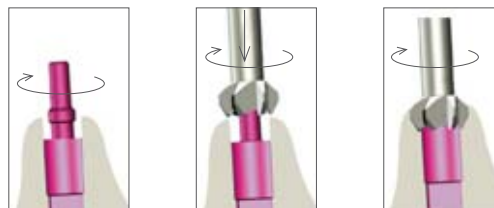

After unscrewing the guide pin, the abutment is inserted into the lab analog.



# TEMPORARY RESTORATIONS

## PRODUCT DESCRIPTION

### TEMPORARY ABUTMENT

The Temporary Abutment, PEEK (PEEK=polyether ether keton), is designed for use in esthetic restorations. It can also be used for long-term provisionals up to 6 months as needed. The benefits of immediate implantation with an esthetic, non-functional immediate restoration consist in preservation of the structures of the periodontal or peri-implant tissue in esthetically critical zones. Once an adequate healing (osseointegration) period for the implant has elapsed and the peri-implant soft tissue has matured, a new impression for the final restoration can be taken.



### EXISTING TEMPORARY ABUTMENT WITH K ARTICLE NUMBERS (K-SERIES) FOR ALL IMPLANT LINES

Art. No.	K2241.3800	K2241.4300	K2241.5000	K2241.6000
Temporary abutment, preparable, incl. abutment screw				
For implant diameters				

The Temporary Abutment has a prosthetic height of 12.0 mm and is available in implant diameters 3.8/4.3/5.0/6.0 mm.

### TEMPORARY ABUTMENT PS FOR PLATFORM SWITCHING

To make appropriate soft tissue management possible for Platform Switching, healing caps PS are used for healing. This requires the subsequent use of the Temporary Abutment PS for Platform Switching. Like the healing caps PS, these are also tapered in the apical area making it possible to adapt soft tissue over the implant shoulder.



← Apical tapering

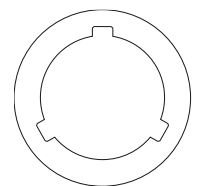

SCREW-LINE Implant K-Series

### TEMPORARY ABUTMENT PS FOR PLATFORM SWITCHING WITH NEW SCREW-LINE IMPLANTS WITH K ARTICLE NUMBERS

Art. No.	K2208.3800	K2208.4300	K2208.5000	K2208.6000
Temporary abutment PS, preparable, incl. abutment screw				
For implant diameters				

The Temporary Abutment PS has a prosthetic height of 12.0 mm and is available in implant diameters 3.8/4.3/5.0/6.0 mm.

# TEMPORARY RESTORATIONS

## NOTE

Fabrication of the temporary suprastructures on CAMLOG® implants with the existing Temporary Abutment and Temporary Abutment PS for Platform Switching is identical.



## FABRICATION OF A TEMPORARY RESTORATION

We recommend that you fabricate the working cast with a gingival mask. Insert the Temporary Abutment into the lab analog in the cast and rotate until the cams engage in the grooves of the lab analog. Insert the lab screw (brown anodized) into the abutment and use a screwdriver (hex) to hand-tighten.



The preparation margins and the occlusal height is marked on the abutment according to the gingival line and tooth length.

**TIP:** After implantation, in the practice the Temporary Abutment can be set into the implant and the ideal preparation line (according to the gingival line, the occlusal height, etc.) marked in the mouth for modification of the abutment.

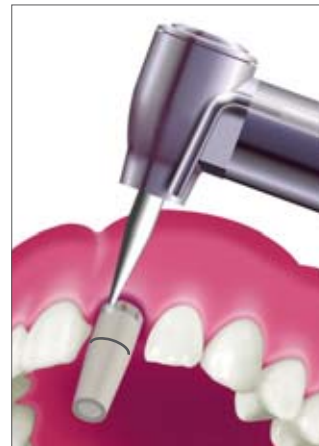

Depending on the marks, the preparation resembles conventional perioprosthetics.



For better handling, the Temporary Abutment can be mounted on a lab analog for grinding or mounted on an abutment collect for the universal holder.



Grinding the abutment on the lab analog

The chamfer or crown margins must lie paragingivally for esthetic immediate restorations, and approx. 1–1.5 mm subgingivally for late restorations to achieve an anatomic emergence profile of the peri-implant tissue.

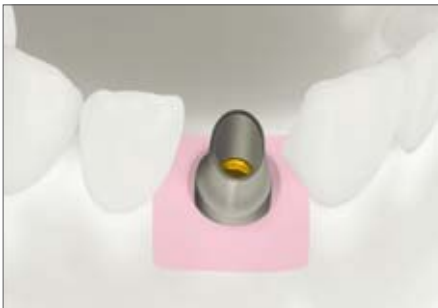

The temporary restoration is then fabricated in the usual manner on the Temporary Abutment.



As needed for a bridge constructions, for example, metal reinforcement can also be integrated in the temporary restoration.

**INSTRUCTIONS FOR BRIDGE RECONSTRUCTIONS**

The insertion directions of the abutments, indicated by the implant axial direction, rarely match. For this reason, bridge structures should not be fabricated in one piece (firmly attached) with the Temporary Abutments. The Temporary Abutments are first mounted on the implants and the temporary bridge is then mounted (passive fit).

**TIP:** A mark is placed on the modified temporary abutment and on the vestibular aspect to facilitate detection of the insertion position of the abutment.

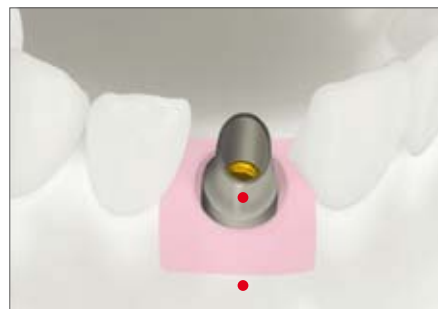

# ESTHOMIC® LINE OF ABUTMENTS

## PRODUCT DESCRIPTION

### ESTHOMIC® ABUTMENTS

With the Esthomic® abutments, cemented crown and bridge restorations can be fabricated for esthetically challenging areas. Esthomic® abutments consist of a titanium alloy, are available in straight and angled versions (15° and 20°, each as Type A and B) and can be modified individually in regards to prosthetic height.

Due to the anatomically appropriate forming of the shoulder and the two selectable gingival heights, individual modifications are reduced in the shoulder area and the processing time shortened. Selectable gingival heights (GH) are 1.0–1.8 mm and 3.0–4.5 mm.

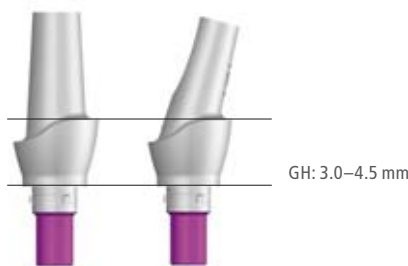
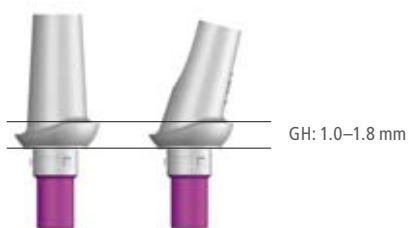

Gingival heights (GH) of Esthomic® abutments, straight and angled

The oval base form of the abutment serves as an antirotational mechanism for single crowns.



Esthomic® abutments are color-coded according to the diameter of the implant and include an abutment screw. Esthomic® abutments are available based on the gingival height in various prosthetic heights (PH x<sup>1</sup>/x<sup>2</sup>, see information in the tables).

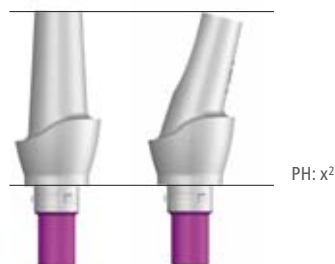
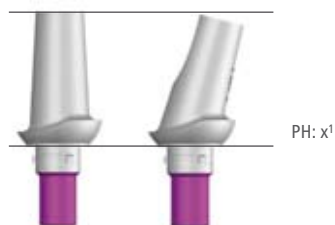

Prosthetic heights (PH) of Esthomic® abutments, straight and angled

For the Platform Switching option, special Esthomic® abutments PS are available.



**ESTHOMIC® ABUTMENTS, STRAIGHT**

Processing of straight and angled Esthomic® abutments is identical.

**ESTHOMIC® ABUTMENT, STRAIGHT, preparable, incl. abutment screw, (Ti6Al4V)**

Art. No.	K2226.3810	K2226.3830	K2226.4310	K2226.4330	K2226.5010	K2226.5030	K2226.6010	K2226.6030
Ø mm	3.8	3.8	4.3	4.3	5.0	5.0	6.0	6.0
GH mm	1.0–1.8	3.0–4.5	1.0–1.8	3.0–4.5	1.0–1.8	3.0–4.5	1.0–1.8	3.0–4.5
PH mm	9.0	11.7	9.0	11.7	9.0	11.7	9.0	11.7

GH: Gingival height (in mm)  
 PH: Prosthetic height (in mm, measured from the implant shoulder support to occlusal abutment edge)

**ESTHOMIC® ABUTMENTS, 15° AND 20° ANGLED, TYPE A AND B**

Angled abutments type A and B are available in the Esthomic® line of abutments. Type A has a cam opposing the angle direction. In contrast to Type A, Type B has a 60° offset cams. Both types make six different rotation positions possible to achieve an optimal prosthetic axis alignment.

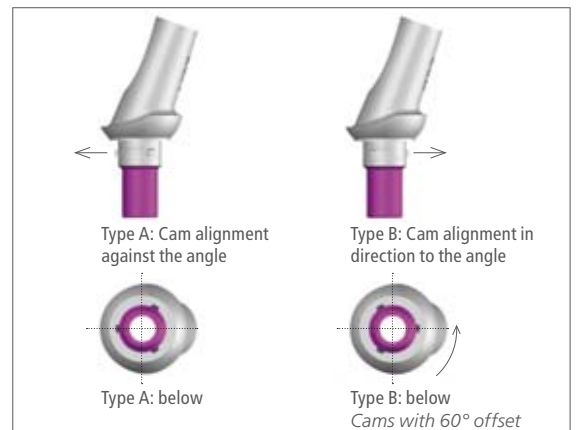

**ESTHOMIC® ABUTMENT, 15° ANGLED, TYPE A, preparable, incl. abutment screw, (Ti6Al4V)**









Art. No.	K2227.3810	K2227.3830	K2227.4310	K2227.4330	K2227.5010	K2227.5030	K2227.6010	K2227.6030
Ø mm	3.8	3.8	4.3	4.3	5.0	5.0	6.0	6.0
GH mm	1.0–1.8	3.0–4.5	1.0–1.8	3.0–4.5	1.0–1.8	3.0–4.5	1.0–1.8	3.0–4.5
PH mm	8.8	11.5	8.8	11.5	9.0	11.7	9.0	11.8

**ESTHOMIC® ABUTMENT, 15° ANGLED, TYPE B, preparable, incl. abutment screw, (Ti6Al4V)**









Art. No.	K2228.3810	K2228.3830	K2228.4310	K2228.4330	K2228.5010	K2228.5030	K2228.6010	K2228.6030
Ø mm	3.8	3.8	4.3	4.3	5.0	5.0	6.0	6.0
GH mm	1.0–1.8	3.0–4.5	1.0–1.8	3.0–4.5	1.0–1.8	3.0–4.5	1.0–1.8	3.0–4.5
PH mm	8.8	11.5	8.8	11.5	9.0	11.7	9.0	11.8

# ESTHOMIC® LINE OF ABUTMENTS

## ESTHOMIC® ABUTMENT, 20° ANGLED, TYPE A, preparable, incl. abutment screw, (Ti6Al4V)

Art. No.	K2231.3810	K2231.3830	K2231.4310	K2231.4330	K2231.5010	K2231.5030	K2231.6010	K2231.6030
								
Ø mm	3.8	3.8	4.3	4.3	5.0	5.0	6.0	6.0
GH mm	1.0–1.8	3.0–4.5	1.0–1.8	3.0–4.5	1.0–1.8	3.0–4.5	1.0–1.8	3.0–4.5
PH mm	8.7	11.4	8.7	11.4	8.9	11.5	9.1	11.9

## ESTHOMIC® ABUTMENT, 20° ANGLED, TYPE B, preparable, incl. abutment screw, (Ti6Al4V)

Art. No.	K2232.3810	K2232.3830	K2232.4310	K2232.4330	K2232.5010	K2232.5030	K2232.6010	K2232.6030
								
Ø mm	3.8	3.8	4.3	4.3	5.0	5.0	6.0	6.0
GH mm	1.0–1.8	3.0–4.5	1.0–1.8	3.0–4.5	1.0–1.8	3.0–4.5	1.0–1.8	3.0–4.5
PH mm	8,7	11,4	8,7	11,4	8,9	11,5	9,1	11,9





GH: Gingival height (in mm)

PH: Prosthetic height (in mm, measured from the implant shoulder support to occlusal abutment edge)

## ESTHOMIC® ABUTMENT, INSET

If space is limited, the Esthomic® abutment, Inset, can be used. The diameter of the abutment shoulder is identical to the corresponding implant diameter. The Esthomic® abutment, Inset, is available in gingival height 1.5–2.8 mm.

## ESTHOMIC® ABUTMENT, INSET, preparable, incl. abutment screw, (Ti6Al4V)

Art. No.	K2235.3315	K2235.3815	K2235.4315	K2235.5015	K2235.6015
					
Ø mm	3.3	3.8	4.3	5.0	6.0
GH mm	1.5–2.8	1.5–2.8	1.5–2.8	1.5–2.8	1.5–2.8
PH mm	9.0	9.0	9.0	9.0	9.0

GH: Gingival height (in mm)

PH: Prosthetic height (in mm, measured from the implant shoulder support to occlusal abutment edge)

**ESTHOMIC® ABUTMENTS PS FOR PLATFORM SWITCHING**

To make appropriate soft tissue management possible for Platform Switching, healing caps PS are used for healing. This requires the subsequent use of the Esthomic® Abutments PS for Platform Switching. Like the healing caps PS, these are also tapered in the apical area making it possible to adapt soft tissue over the implant shoulder.

**ESTHOMIC® ABUTMENTS PS, STRAIGHT**

The processing of straight and angled Esthomic® abutments is identical.

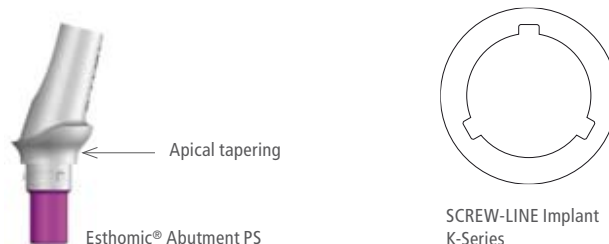

**NOTE:** The fabrication of suprastructures on CAMLOG® implants is identical to with the existing Esthomic® abutments and the Esthomic® abutments PS for Platform Switching.

**ESTHOMIC® ABUTMENT PS, STRAIGHT, preparable, incl. abutment screw, (Ti6Al4V)**

Art. No.	K2202.3815	K2202.4315	K2202.5015	K2202.6015
Ø mm	3.8	4.3	5.0	6.0
GH mm	1.5–2.5	1.5–2.5	1.5–2.5	1.5–2.5
PH mm	9.7	9.7	9.7	9.7

**ESTHOMIC® ABUTMENTS PS, 15° ANGLED, TYPE A AND B**

The Esthomic® abutments PS, angled, for Platform Switching, are available with 15° angle in type A and B.

**ESTHOMIC® ABUTMENT PS, 15° ANGLED, TYPE A, preparable, incl. abutment screw, (Ti6Al4V)**

Art. No.	K2203.3815	K2203.4315	K2203.5015	K2203.6015
Ø mm	3.8	4.3	5.0	6.0
GH mm	1.5–2.5	1.5–2.5	1.5–2.5	1.5–2.5
PH mm	9.5	9.6	9.5	9.6

**ESTHOMIC® ABUTMENT PS, 15° ANGLED, TYPE B, preparable, incl. abutment screw, (Ti6Al4V)**

Art. No.	K2204.3815	K2204.4315	K2204.5015	K2204.6015
Ø mm	3.8	4.3	5.0	6.0
GH mm	1.5–2.5	1.5–2.5	1.5–2.5	1.5–2.5
PH mm	9.5	9.6	9.5	9.6

GH: Gingival height (in mm)  
 PH: Prosthetic height (in mm, measured from the implant shoulder support to occlusal abutment edge)

# ESTHOMIC® LINE OF ABUTMENTS

## ESTHOMIC® SELECTION ABUTMENTS

After fabricating the master cast, the Esthomic® abutments suitable for the suprastructures can be quickly and easily selected using the color-coded Esthomic® selection abutments in the dental laboratory. There is no longer any need for expensive and complicated storage of the original abutments, either by the dentist or at the prosthodontist or dental laboratory.

The Esthomic® selection abutments are identical in geometry to the original Esthomic® abutments. The Esthomic® selection abutments are made of plastic, have only one cam and are fully pigmented. All Esthomic® selection abutments are available in the CAMLOG® selection abutment kit and separately in a 2-piece pack.

The appropriate abutments are selected on the master cast. The implant axis, groove position, gingival line/thickness and implant diameter are taken into account. The selection abutments can be inserted directly into the lab analog and are reusable.

**CAUTION**  
Esthomic® selection abutments may not be used on the patient!















CAMLOG® selection abutment set

**NOTE**









The Esthomic® abutments for diameter 6.0 mm are selected using the blue selection abutments with diameter 5.0 mm.

## ESTHOMIC® SELECTION ABUTMENTS, STRAIGHT









SELECTION ABUTMENT	ORIGINAL ABUTMENT
 <p>straight</p> <p>Art. No.: K3526.3810</p>	 <p>Ø 3.8 mm GH: 1.0–1.8 mm PH: 9.0 mm</p> <p>Art. No.: K2226.3810</p>
 <p>straight</p> <p>Art. No.: K3526.4310</p>	 <p>Ø 4.3 mm GH: 1.0–1.8 mm PH: 9.0 mm</p> <p>Art. No.: K2226.4310</p>
 <p>straight</p> <p>Art. No.: K3526.5010</p>	 <p>Ø 5.0 mm GH: 1.0–1.8 mm PH: 9.0 mm</p> <p>Art. No.: K2226.5010</p>

SELECTION ABUTMENT	ORIGINAL ABUTMENT
 <p>straight</p> <p>Art. No.: K3526.3830</p>	 <p>Ø 3.8 mm GH: 3.0–4.5 mm PH: 11.7 mm</p> <p>Art. No.: K2226.3830</p>
 <p>straight</p> <p>Art. No.: K3526.4330</p>	 <p>Ø 4.3 mm GH: 3.0–4.5 mm PH: 11.7 mm</p> <p>Art. No.: K2226.4330</p>
 <p>straight</p> <p>Art. No.: K3526.5030</p>	 <p>Ø 5.0 mm GH: 3.0–4.5 mm PH: 11.7 mm</p> <p>Art. No.: K2226.5030</p>









**ESTHOMIC® SELECTION ABUTMENTS, 15° ANGLED**









SELECTION ABUTMENT	ORIGINAL ABUTMENT	
 15° A	 Ø 3.8 mm GH: 1.0–1.8 mm PH: 8.8 mm	 Ø 3.8 mm GH: 3.0–4.5 mm PH: 11.5 mm
Art. No.: K3527.3810	K2227.3810	K2227.3830
 15° A	 Ø 4.3 mm GH: 1.0–1.8 mm PH: 8.8 mm	 Ø 4.3 mm GH: 3.0–4.5 mm PH: 11.5 mm
Art. No.: K3527.4310	K2227.4310	K2227.4330
 15° A	 Ø 5.0 mm GH: 1.0–1.8 mm PH: 9.0 mm	 Ø 5.0 mm GH: 3.0–4.5 mm PH: 11.7 mm
Art. No.: K3527.5010	K2227.5010	K2227.5030

The Esthomic® selection abutments, straight, are used to select the gingival height.

SELECTION ABUTMENT	ORIGINAL ABUTMENT	
 15° B	 Ø 3.8 mm GH: 1.0–1.8 mm PH: 8.8 mm	 Ø 3.8 mm GH: 3.0–4.5 mm PH: 11.5 mm
Art. No.: K3528.3810	K2228.3810	K2228.3830
 15° B	 Ø 4.3 mm GH: 1.0–1.8 mm PH: 8.8 mm	 Ø 4.3 mm GH: 3.0–4.5 mm PH: 11.5 mm
Art. No.: K3528.4310	K2228.4310	K2228.4330
 15° B	 Ø 5.0 mm GH: 1.0–1.8 mm PH: 9.0 mm	 Ø 5.0 mm GH: 3.0–4.5 mm PH: 11.7 mm
Art. No.: K3528.5010	K2228.5010	K2228.5030

**ESTHOMIC® SELECTION ABUTMENTS, 20° ANGLED**

SELECTION ABUTMENT	ORIGINAL ABUTMENT	
 20° A	 Ø 3.8 mm GH: 1.0–1.8 mm PH: 8.7 mm	 Ø 3.8 mm GH: 3.0–4.5 mm PH: 11.4 mm
Art. No.: K3531.3810	K2231.3810	K2231.3830
 20° A	 Ø 4.3 mm GH: 1.0–1.8 mm PH: 8.7 mm	 Ø 4.3 mm GH: 3.0–4.5 mm PH: 11.4 mm
Art. No.: K3531.4310	K2231.4310	K2231.4330
 20° A	 Ø 5.0 mm GH: 1.0–1.8 mm PH: 8.9 mm	 Ø 5.0 mm GH: 3.0–4.5 mm PH: 11.5 mm
Art. No.: K3531.5010	K2231.5010	K2231.5030

SELECTION ABUTMENT	ORIGINAL ABUTMENT	
 20° B	 Ø 3.8 mm GH: 1.0–1.8 mm PH: 8.7 mm	 Ø 3.8 mm GH: 3.0–4.5 mm PH: 11.4 mm
Art. No.: K3532.3810	K2232.3810	K2232.3830
 20° B	 Ø 4.3 mm GH: 1.0–1.8 mm PH: 8.7 mm	 Ø 4.3 mm GH: 3.0–4.5 mm PH: 11.4 mm
Art. No.: K3532.4310	K2232.4310	K2232.4330
 20° B	 Ø 5.0 mm GH: 1.0–1.8 mm PH: 8.9 mm	 Ø 5.0 mm GH: 3.0–4.5 mm PH: 11.5 mm
Art. No.: K3532.5010	K2232.5010	K2232.5030

The Esthomic® selection abutments, straight, are used to select the gingival height.

GH: Gingival height (in mm)

PH: Prosthetic height (in mm, measured from the implant shoulder support to occlusal abutment edge)

# ESTHOMIC® LINE OF ABUTMENTS

## PROCESSING OF THE ESTHOMIC® ABUTMENTS

### INDIVIDUAL PROCESSING/PREPARATION (EXAMPLE OF CEMENTED SINGLE CROWN)

After selecting the suitable Esthomic® abutment, it is individually modified on the plaster cast in consideration of the anatomical conditions.

To prepare the abutment and to fabricate the suprastructure on the plaster cast, the brown anodized lab screw should be used.



Lab screw

The silicone index prepared in the planning phase is used on the plaster cast for visualization of the desired prosthetic design and as support for achieving the optimal forming of the abutment.

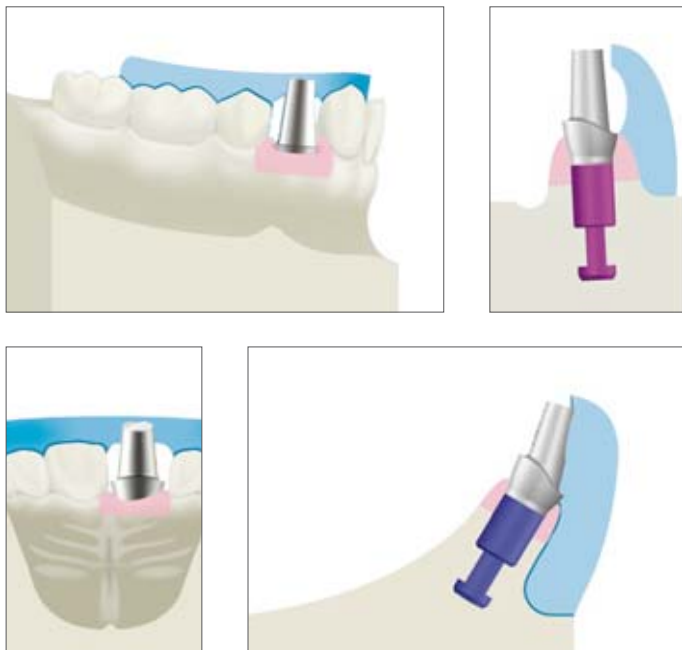

The course of the preparation edge, as well as the height and axial alignment are marked.



To simplify processing the abutment, the universal holder can be used with diameter-matched, color-coded abutment collects. The integrated clamping screw (hex) fixes the required insert (abutment collect) in the handle and the lab screw secures the abutment in the insert.

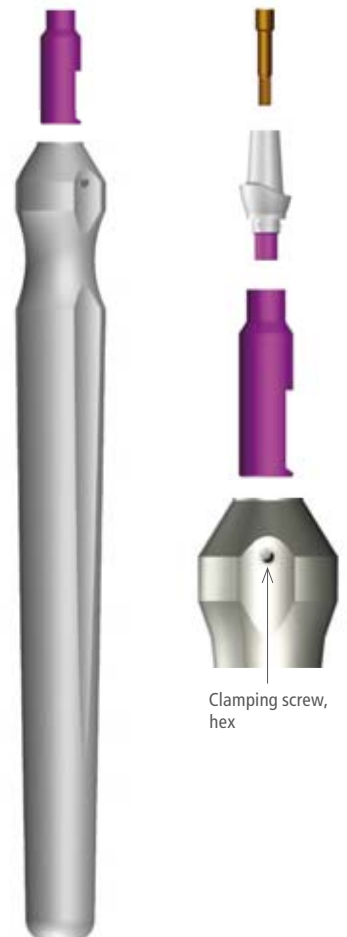

**PROCESSING**

Abrasive particles suitable for titanium machining are used for the preparation. For fine preparation and to create the chamfer, we recommend finely toothed titanium milling cutter. For grinding, the speeds recommended by the respective manufacturer of the abrasive particles should be maintained. Use only low pressure to avoid overheating the titanium. Overheating causes a heavy "alpha-case" layer to form. It is very hard and can make further processing difficult.

First, the abutment height and axial inclination are adapted, then followed by preparation similar to standard chamfer preparation of a tooth stump based on the perioprosthetics. The ideal preparation angle is approx. 2–4°. For esthetic reasons, the crown margin should lie vestibular 1–1.5 mm subgingivally.

**CAUTION**

To safely remove any remaining cement, the cement gap should not lie deeper than 1.5–2.0 mm subgingivally for cemented restorations.

During the preparation process, we recommend to return the abutment into the cast and use the silicone index to check the forming. At the conclusion of the modification, the ground surface is smoothed (e.g. with a gumming unit).

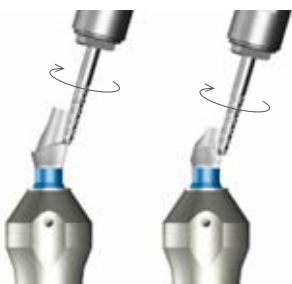

**TIP:** To make later integration of the crown easier and to ensure antirotational support, the preparation cross-section should not circular, but oval similar to the root cross-section of the natural teeth and include a milled conical guide groove.

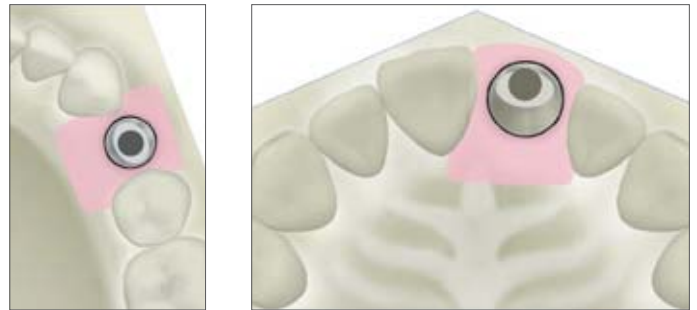

**TIP:** To make orientation/alignment easier when inserting the abutment into the mouth, a mark in the form of a milled depression on the vestibular side can be attached. This mark is also transferred to the plaster cast and makes handling on the cast easier in practice. This is particularly helpful with several abutments.

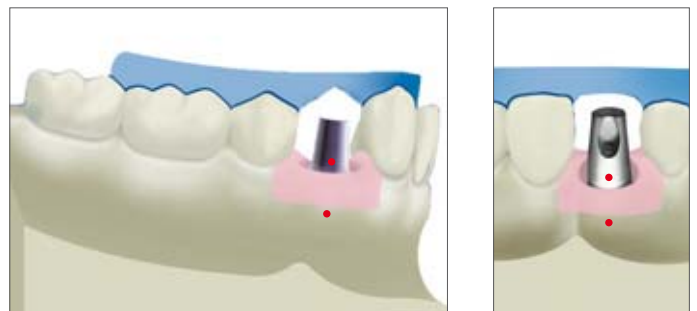

# ESTHOMIC® LINE OF ABUTMENTS

## FABRICATION OF A CEMENTABLE CROWN ON AN ESTHOMIC® ABUTMENT

After completing the modifications, the abutment can be prosthetically restored.

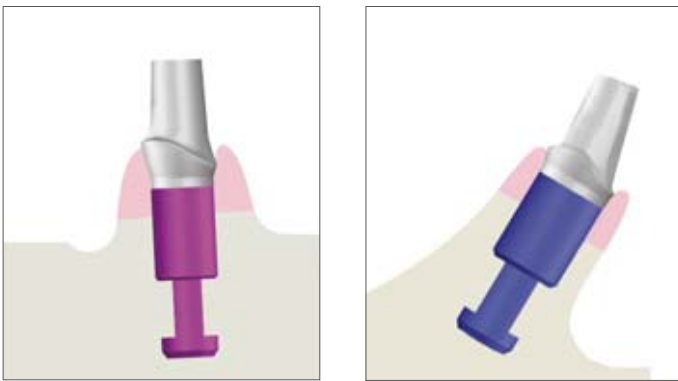

Before constructing of a wax or plastic cap, the screw head must be covered with a soft material and the screw channel closed with a removable material.



Covering the screw head

Closing the screw channel

The abutment is coated with suitable separating medium. The wax-up is carried out in the conventional manner similar to perioprosthodontics in consideration of function, esthetics and hygienic potential.

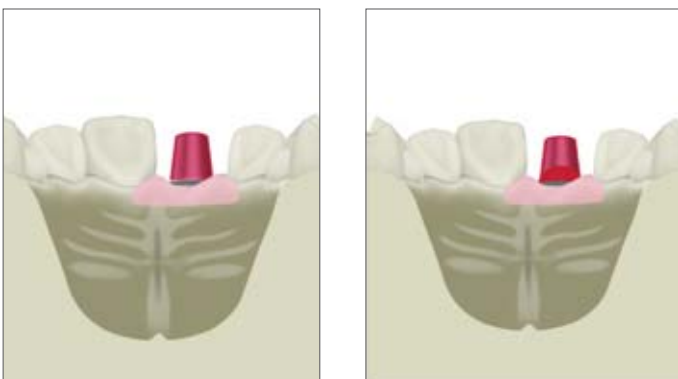



**TIP:** So that the cast crown framework for veneering can be held with an artery clip and for a better removing from the abutment for the framework try-in, we recommend attaching a thin wax wire on the palatal/lingual area for the wax-up. In practice, the wire also cast can then be removed before the final insertion.



After the cast is made, the crown is veneered and completed.



**TIPP:** A vestibular mark makes orienting/aligning easier when inserting the crown in the mouth. This should be identical to the marks made previously on the abutment and cast. This is particularly helpful with several abutments/crowns.

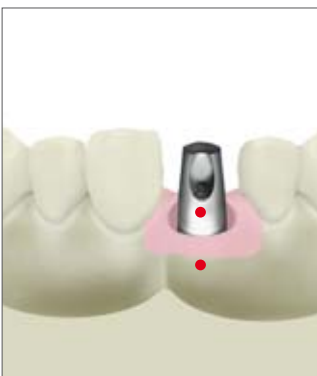

**INSERTING THE ESTHOMIC® ABUTMENT AND THE CEMENTABLE CROWN**

Clean and disinfect the prosthetic components prior to insertion. Clean the internal configuration of the implant with water spray, check for residues and allow to dry. The peri-implant hard and soft tissue situation must allow gapless insertion of the Esthomic® abutment and crown.

To insert, the abutment mark is vestibularly oriented and the tube of the abutment slid into the implant. After seating the cams on the implant shoulder, the abutment can be easily turned until the cams noticeably slide into the grooves of the implant. The abutment sinks 1.2 mm into the internal configuration of the implant.

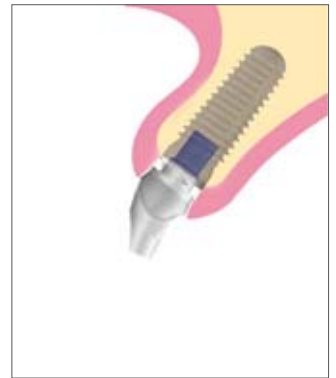

# ESTHOMIC® LINE OF ABUTMENTS

The abutment screw is inserted into the screw channel and tightened with a screwdriver (hex) and the torque wrench with a force of 20 Ncm.

We recommend that you retighten the abutment screw after 5 minutes with the same force to achieve maximum pre-tension on the screws. Only use new abutment screws.

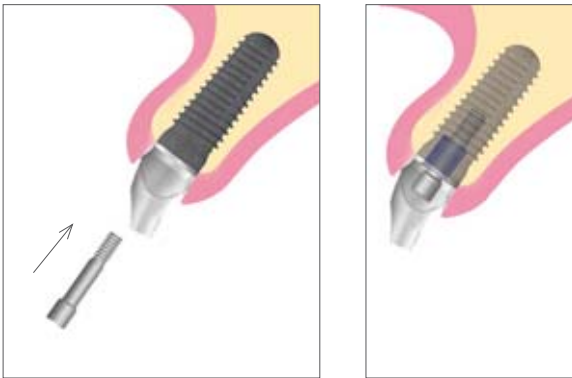

Abutment screw

After tightening the abutment screw, use a reusable material to close the screw channel concave. A convex overage should be avoided as this would negatively affect the correct seat of the crown.

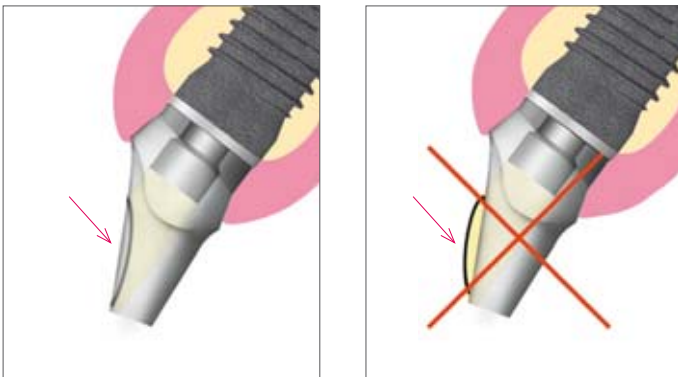

Before cementing, the abutment and crown are cleaned and dried in the usual manner. We recommend phosphate and carboxylate cements for the final cementation. Manufacture instructions must be observed. To avoid an air cushion, only a thin layer of cement should be brushed into the crown.

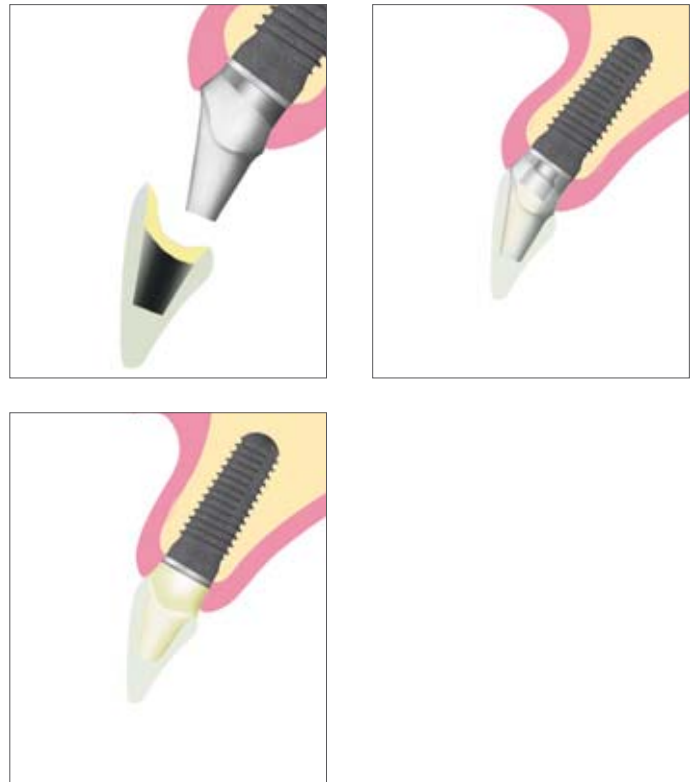

#### IMPORTANT NOTE

Cement residues in the sulcus must be carefully removed.

#### ALL-CERAMIC CROWNS

All-ceramic crowns are conditioned and cemented/bonded according to the specifications of the respective ceramic manufacturer.

### INDIVIDUAL PROCESSING/PREPARATION (EXAMPLE OF CEMENTED BRIDGE)

After implantation, the implant axes of the implants in the jaw rarely match. Therefore, a uniform insertion direction for the individual abutments must be found for fabricating a bridge construction on Esthomic® abutments. The abutments must be modified in their prosthetic area accordingly.



#### IMPORTANT NOTE

The insertion direction may not be achieved by grinding the Tube-in-Tube™ connection (e.g. shorten the tube). This would destroy the precision fit of the abutment in the implant.

The suitable Esthomic® abutments are set in the lab analogs and manually fixed with lab screws. The gingival line is then marked to define the crown margin and occlusal abutment height.



The cast is inserted into a parallelometer or milling machine. The uniform insertion direction of the individual abutments is checked and determined.



The uniform insertion direction of the abutments are prepared:

- Manually in the universal holder with alternating control of the master cast loaded in the parallelometer
- On the plaster cast/milling cast loaded in the milling machine

**TIP:** To protect the plaster cast when processing the Esthomic® abutments, we recommend that you fabricate a corresponding milling cast.

# ESTHOMIC® LINE OF ABUTMENTS

## FABRICATING A MILLING CAST:

To transfer the cast situation to an individually fabricated milling base, impression posts, open tray and lab analogs corresponding to the implant diameter are required (see color-coding). The impression posts are mounted to the lab analogs in the cast. Note the proper seating.



The posts are firmly attached with a transfer assistance with cold-curing plastic in the retentive area (NOT on the fixing screw). After the plastic has cured, loosening and completely backing out the fixing screw, the transfer assistance with the impression posts is removed from the cast.

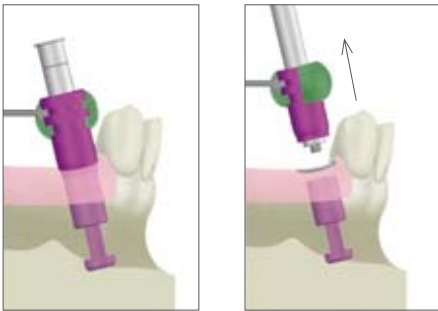

The impression posts are bolted together with the appropriate lab analogs and inserted in a milling disk filled with super-hard dental stone.

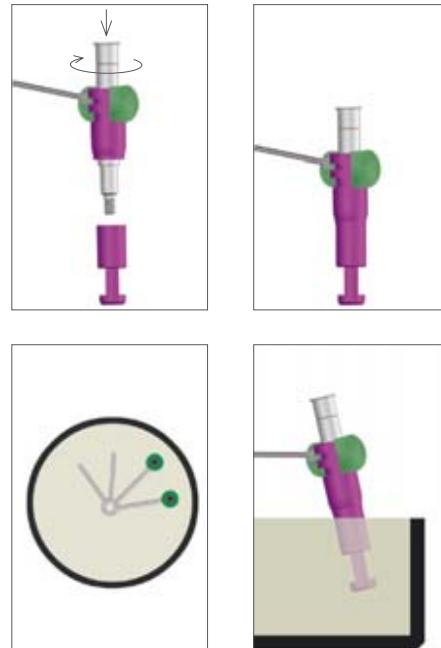

The uniform insertion direction previously determined on the master cast represents the milling axis.

**PROCESSING:**

The abutment heights and axial inclinations are adapted, then followed by preparation similar to standard chamfer preparation of a tooth stump based on the perioprosthetics. The ideal preparation angle is approx. 2–4°. For esthetic reasons, the crown margin should lie vestibular 1–1.5 mm subgingivally.

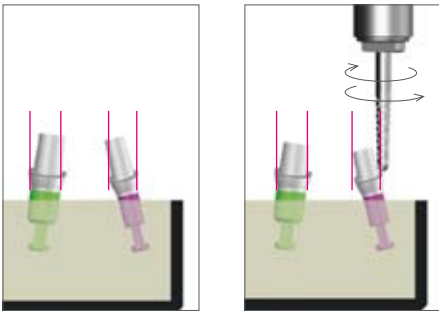

Fabrication of a bridge construction on Esthomic® abutments is identical to "Fabrication of a cementable crown" as described on page 32.



**CAUTION**

To safely remove any remaining cement, the cementable gap should not lie deeper than 1.5–2.0 mm subgingivally for cemented restorations.

During the preparation process, we recommend to return the abutment into the cast and use the silicone index to check the forming.

At the conclusion of the modification, the ground surface is smoothed (e.g. with a gumming unit).



The modified Esthomic® abutments and fabricated bridge construction is cleaned and inserted (see also description on page 33, "Inserting the Esthomic® abutment and the cementable crown").

**IMPORTANT NOTE**

In most casts, implant axis divergences cannot be ruled out for the implantation. Therefore, abutments may not be primarily splinted together e.g. by laser welding due to the precise Tube-in-Tube™ connection. A bridge construction always has to be bonded/cemented over the abutments.

# UNIVERSAL ABUTMENT

## PRODUCT DESCRIPTION

### UNIVERSAL ABUTMENT

The Universal abutment can be used for individually fabricated cementable crown and bridge restorations as well as telescopic crown restorations. The Universal Abutment is made of a titanium alloy and can be custom trimmed. Divergences of max. 20° to the implant axis can be compensated for by a suitably adapted forming and bridge restorations inserted.

For the Platform Switching option, special Universal abutments PS are available.



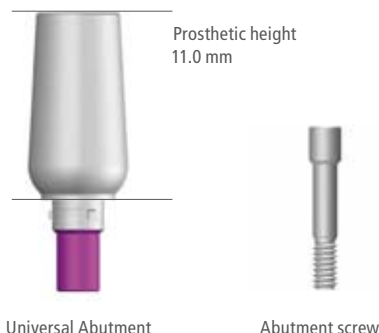

Universal abutments are color-coded by implant diameter. All universal abutments are supplied with an abutment screw.



### IMPORTANT NOTE

The Universal abutment with diameter 3.3 mm is not suitable for telescopic crown restorations due to stability reasons.

### UNIVERSAL ABUTMENT, preparable, incl. abutment screw, (Ti6Al4V)

Art. No.	K2211.3300*	K2211.3800	K2211.4300	K2211.5000	K2211.6000
					
Ø mm	3.3	3.8	4.3	5.0	6.0
PH mm	11.0	11.0	11.0	11.0	11.0

\* Only for crown restorations in the area of the upper lateral incisors and lower lateral and central incisors

PH: Prosthetic height (in mm, measured from the implant shoulder support to occlusal abutment edge)

**UNIVERSAL ABUTMENT PS FOR PLATFORM SWITCHING**

To make appropriate soft tissue management possible for Platform Switching, healing caps PS are used for healing. This requires the subsequent use of the Universal abutment PS for Platform Switching. Like the healing caps PS, these are also tapered in the apical area making it possible to adapt soft tissue over the implant shoulder.

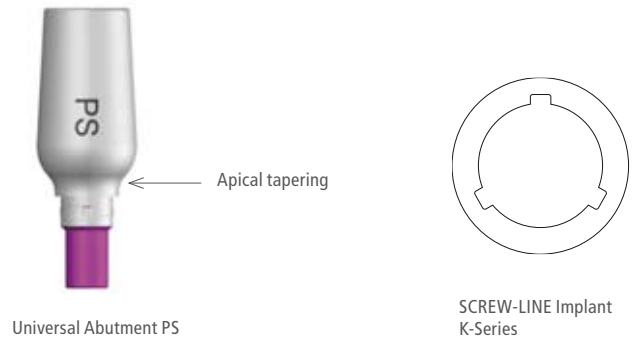

**UNIVERSAL ABUTMENT PS, preparable, incl. abutment screw, (Ti6Al4V)**

Art. No.	K2201.3800	K2201.4300	K2201.5000	K2201.6000
Ø mm	3.8	4.3	5.0	6.0
PH mm	11.0	11.0	11.0	11.0

PH: Prosthetic height (in mm, measured from the implant shoulder support to occlusal abutment edge)

**INDIVIDUAL PROCESSING/PREPARATION OF THE UNIVERSAL ABUTMENT**

After selecting the suitable Universal abutment for the planned prosthetic restoration, it is individually modified on the plaster cast in consideration of the anatomical conditions.

To prepare the abutment and to fabricate the suprastructure on the plaster cast, the brown anodized lab screw should be used.

Preparation, manufacture of the crown or bridge restoration and insertion are similar to the abutments of the Esthomic® line of abutments as described under "Processing the Esthomic® abutments" on pages 30–37.



Lab screw

# GOLD-PLASTIC ABUTMENT

## PRODUCT DESCRIPTION

The Gold-plastic abutment consists of a prefabricated cast-on base part made of a high-melting cast-on gold alloy and a screw channel made of burn-out plastic (POM).

The screw channel represents a modeling aid and ensures a clean finish of the screw channel. The screw channel is color-coded, firmly connected to the base part and can be individually shortened occlusally.

The Gold-plastic abutment can be used to fabricate single-crowns, individual implant abutments (mesostructures) for cementable bridge restorations and primary abutments for bridging implant axis divergences in the telescopic crown technique using the cast-on technique.

The high-melting cast-on gold alloy is only suitable for the cast-on procedure with high-gold alloys.

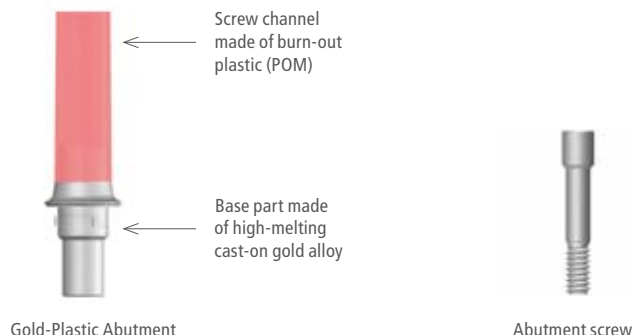

### GOLD-PLASTIC ABUTMENT, cast-on, incl. abutment screw

Art. No.	K2246.3300*	K2246.3800	K2246.4300	K2246.5000	K2246.6000
Ø mm	3.3	3.8	4.3	5.0	6.0
PH mm	11.0	11.0	11.0	11.0	11.0
Noble metal weight of the base part approx.	0,42 g	0,46 g	0,65 g	0,81 g	0,89 g

\* Only for crown restorations in the area of the upper lateral incisors and lower lateral and central incisors

PH: Prosthetic height (in mm, measured from the implant shoulder support to occlusal abutment edge)

## PROCESSING (EXAMPLE: ALL CERAMIC CROWN)

### MODIFICATION OF THE SCREW CHANNEL

The Gold-plastic abutment is set into the lab analog and a screwdriver (hex) used to hand-tighten the lab screw. The abutment must sit correctly in the Tube-in-Tube™ connection. Using a previously prepared silicone index, the required height of the screw channel is indicated and shortened accordingly.



Lab screw

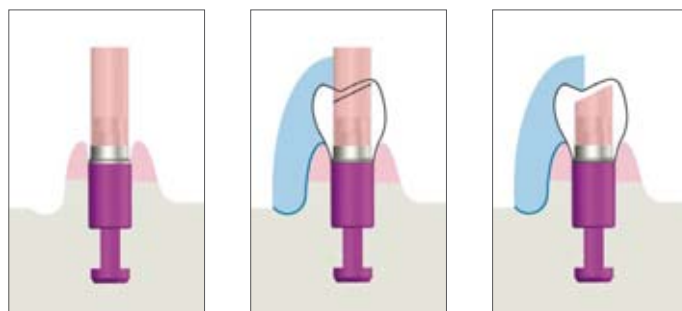



**WAX-UP**

The framework is waxed up in the usual manner according to the design of the "reduced crown shape". Take care that adequate and uniform ceramic layer can be achieved for the veneering.

The minimum wax thickness over the base part must be 0.7 mm to achieve an optimal discharge behavior of the cast-on alloy and to ensure the minimum thickness. The base part consists of a non-oxidizing high-melting cast-on gold alloy and therefore cannot be ceramically veneered (no adhesive oxide formation and a different heat expansion coefficient of the ceramic lead to crack formation in the bonding ceramic).

The ideal framework form can be controlled with the previously prepared silicone index.

**TIP:** To prevent non-axial loads and over contouring in the posterior area, we recommend reducing the wax-up to premolar size.

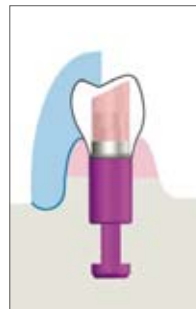
**CAUTION**

Do not carve over the fine gold margin (0.3 mm). This can lead to a surplus of cast-on alloy over the margin or onto the implant shoulder support.

After the wax-up is finished, a suitable agent must be used to clean the fine gold margin and the area of the implant shoulder support of separating medium and wax particles (e.g. with a cotton swab soaked in alcohol).

**IMPORTANT NOTE**

Due to the precise fit of the Tube-in-Tube™ connection, Gold-plastic abutments may not be primarily splinted together (e.g. as a one-piece cast bridge construction)!

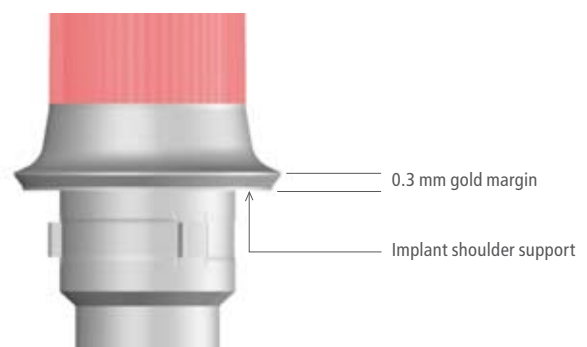

# GOLD-PLASTIC ABUTMENT

## EMBEDDING AND CASTING

The abutment is embedded according to the instruction manual of the muffle system used. We do not recommend the use of a wax wetting agents. The fine film from the agent can lead to a surplus of cast-on alloy over the margin or onto the implant shoulder support. When embedding, the correct placement of the wax-up in the casting muffle is of importance. Volume ratios and pin angles must be selected so that the required temperature for formation of a metallic connection is achieved. This is particularly important for voluminous casts.



The investment material must be matched with the cast-on alloy and the casting alloy used. We recommend phosphate bound investment materials. The manufacturer's processing instructions must be observed and the mixing ratios and preheating times accurately observed. We recommend you do not use any quick heating processes (speed investment materials). The cast delay time must be kept as brief as possible.

## INSTRUCTIONS FOR THE CAST-ON ALLOYS

The casting alloy may not exceed the liquidus temperature of 1350°C (2462°F) in its melting range. The melting range of the high-melting cast-on gold alloy lies between 1400°C–1490°C (2552°F–2714°F).

The cast-on alloy components must be highly gold-bearing and be compatible with the high-melting cast-on gold alloy for the cast-on technique. Observe the instructions of the alloy manufacturer.

The use of other cast-on alloys is not recommended because gold alloys with nickel or cobalt components can destroy the base part.

Components of an unsuitable alloy can lead to phases with reduced corrosion resistance, less stability or a low melting range thanks to "diffusion processes" in the border zone "casting alloy/cast-on alloy".

## DEVESTMENT

After casting, the cast object must be slowly cooled to room temperature and the object gently devested.

### IMPORTANT NOTE

Never use sandblasting to devest the cast; this would destroy the precise fit of the abutment to the implant shoulder (reduction of the precise fit of the Tube-in-Tube™ connection, poor margin fit)!

We recommend gentle devestment in an ultrasonic bath with waterjet or stripping.

## CASTING QUALITY

If the cast object exhibits casting defects after deinvestment such as incomplete effluence or casting fins/bubbles over the margin onto the implant shoulder support, the work should be repeated. The precision of the prefabricated base part is severely affected and also the long-term success of the prosthetic restoration.

## TRIMMING AND VENEERING

To prevent tension cracks in the ceramic, the minimum metal thickness of the metal ceramic alloy must not fall below 0.3 mm in the cast-on area of the base part. If the cast-on alloy is ground through, the work must be repeated because the alloy of the base part does not form any adhesive oxides during the ceramic firing which leads to cracks in the ceramic.

**TIP:** We recommend the use of a stereo microscope.

After trimming, the cast object is prepared for ceramic veneering. To protect the implant shoulder support and Tube-in-Tube™ connection, the cast object should be screwed onto a lab analog before sandblasting.

The ceramic to be used must be compatible with the cast-on alloy (observe heat expansion coefficient). The occlusal surface should be designed based on the "Freedom in centric" concept.

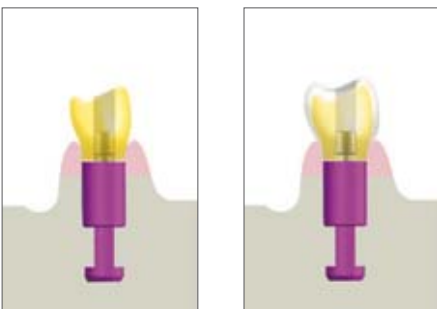

# TITANIUM BASE CAD/CAM

## PRODUCT DESCRIPTION

### TITANIUM BASE CAD/CAM FOR FABRICATING INDIVIDUAL MESOSTRUCTURES USING CAD/CAM TECHNIQUES



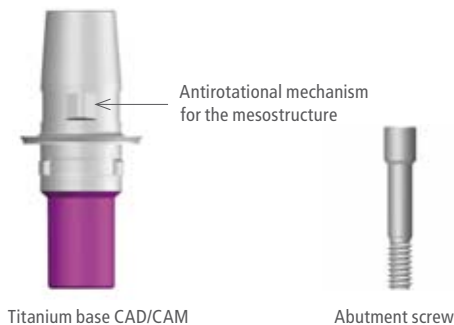

The CAMLOG® titanium base CAD/CAM makes restorations with individual and highly precise abutments made of zirconia ceramic on CAMLOG® implants possible.

The titanium base CAD/CAM is used as a bonding base for individual implant-supported reconstructions such as mesostructures for the crown and bridge technique and telescopic crown technique made of zirconia ceramic.

The CAMLOG® titanium base CAD/CAM can be scanned using current dental scanners and the digitally captured geometries used in the fabrication of mesostructures with CAD/CAM techniques.



### TITANIUM BASE CAD/CAM, incl. abutment screw, (Ti6Al4V)

Art. No.	K2244.3348*	K2244.3848	K2244.4348	K2244.5048	K2244.6048
					
Ø mm	3.3	3.8	4.3	5.0	6.0
PH mm	5.1	5.0	5.0	5.0	5.0

\* Only for mesostructures in the area of the upper lateral incisors and lower lateral and central incisors  
 PH: Prosthetic height (in mm, measured from the implant shoulder support to occlusal base edge)

#### IMPORTANT NOTE

Due to the precise fit of the Tube-in-Tube™ connection, titanium bases CAD/CAM may not be primarily splinted together.

## PROCESSING

The titanium bases CAD/CAM are set in the lab analogs after cast fabrication and the lab screws hand-tightened using the screwdriver (hex). The titanium bases must sit correctly in the Tube-in-Tube™ connection. The antirotational mechanism for the mesostructure should be aligned palatal/lingual. Therefore a maximum wall thickness of the mesostructure is achieved on the vestibular side.



Before scanning, the screw channel is closed using a removable material and the undercut of the antirotational mechanism blocked out. The surface to be scanned is sprayed with Scanspray.

The CAMLOG® titanium bases CAD/CAM in the cast are scanned using a current dental scanner. Using CAD/CAM techniques, the digitally captured geometry is used to fabricate a mesostructure out of zirconia ceramic.

### **BONDING OF THE MESOSTRUCTURE WITH THE TITANIUM BASE CAD/CAM**

After fabricating a mesostructure out of zirconia ceramic, the bonding surface of the titanium base CAD/CAM is blasted with 50 µm aluminum oxide at max. 2.0 bar. Then ablate the bonding surface or clean with alcohol (adhesive surface must be free of dust and grease).

The processing instructions of the manufacturer of the zirconia ceramic must be observed.

**TIP:** For blasting and bonding, it is recommended that the titanium base be attached to a lab analog to protect the implant shoulder support and for easier handling. To prevent the seepage of bonding material, the hex head of the lab screw should be covered with an easily removable material (e.g. wax).

“PANAVIA™ F 2.0” bonding material is used to bind the components. The bonding material is mixed according to manufacturer’s instructions and applied to the titanium base CAD/CAM. The individually fabricated mesostructure is mounted and turned until the antirotational mechanism engages. Then press the mesostructure onto the titanium base as far as it will go. Excess bonding material must be removed immediately.

#### **IMPORTANT NOTE**

The mesostructure out of zirconia ceramic and the titanium base CAD/CAM must be bonded with «PANAVIA™ F 2.0» bonding material ([www.kuraray-dental.eu](http://www.kuraray-dental.eu)). Only this bonding material is suitable for bonding components.

You may chose between light curing or chemical curing. Applying the oxygen blocker “OXYGUARD” ([www.kuraray-dental.eu](http://www.kuraray-dental.eu)) to the titanium/ceramic transition (cervical and in the screw channel) prevents oxygen exposure. Observe the manufacturer’s instructions.

After curing, a rubber polisher can be used to remove the overages.

The titanium base CAD/CAM with bonded mesostructure can be set in the implant and finally provided with the superstructure (all-ceramic crown/bridge, telescopic crown structure).

# CERAMIC ABUTMENT

## PRODUCT DESCRIPTION

The ceramic abutment represents a 2-part abutment and consists of a titanium base and a zirconium oxide sleeve. Zirconium oxide distinguishes itself by an extremely high strength and hardness. The titanium base is equipped with the CAMLOG® Tube-in-Tube™ connection and thus ensures a high precision fit to the implant.



The zirconium oxide sleeve can be individually ground and is used as the mesostructure for the final crown or bridge restoration. Optionally, the zirconium oxide sleeve can directly veneered with appropriate ceramic materials to fabricate an all-ceramic crown. Only after processing or veneering is the sleeve bonded finally to the screwed titanium base. Thus, the titanium base is not exposed to any thermal influences.

Due to the design of the titanium base, the abutment screw head is provided in the metal counter bearing of the titanium base after the final installation into the implant. Mechanical tension in the area of the zirconium oxide sleeve are thereby avoided.

### CERAMIC ABUTMENT, preparable, incl. titanium base (Ti6Al4V), zirconium oxide sleeve and abutment screw

Art. No.	K2242.3340*	K2242.3840	K2242.4340	K2242.5040	K2242.6040
Ø mm	3.3	3.8	4.3	5.0	6.0
PH mm	12.4	12.3	12.3	12.3	12.3

The components of the ceramic abutment are also available individually:

### ZIRCONIUM OXIDE SLEEVE, for ceramic abutment, preparable

Art. No.	J2242.3341*	J2242.3841	J2242.4341	J2242.5041	J2242.6041
Ø mm	3.3	3.8	4.3	5.0	6.0
Sleeve height mm	12.0	12.0	12.0	12.0	12.0

### TITANIUM BASE, for ceramic abutment, (Ti6Al4V)

Art. No.	K2242.3342*	K2242.3842	K2242.4342	K2242.5042	K2242.6042
Ø mm	3.3	3.8	4.3	5.0	6.0
PH mm	3.1	3.0	3.0	3.0	3.0

#### IMPORTANT NOTE

Due to the precise fit of the Tube-in-Tube™ connection, ceramic abutments may not be primarily splinted together.

\* Only for crown restorations in the area of the upper lateral incisors and lower lateral and central incisors  
PH: Prosthetic height (in mm, measured from the implant shoulder support to occlusal abutment edge)

## PROCESSING

### DETERMINATION OF THE ABUTMENT FORM

The titanium base is set in the lab analog and a screwdriver (hex) used to hand-tighten the lab screw. The titanium base must sit correctly in the Tube-in-Tube™ connection. The antirotational mechanism for the zirconium oxide sleeve should be aligned palatinal/lingual. Therefore a maximum wall thickness is achieved on the vestibular side. The zirconium oxide sleeve is then placed on the titanium base and turned until the antirotational mechanism engages.



Using a previously prepared silicone index, the required abutment height and form is indicated on the zirconium oxide sleeve. The shoulder line should lie vestibular 1–1.5 mm subgingivally.

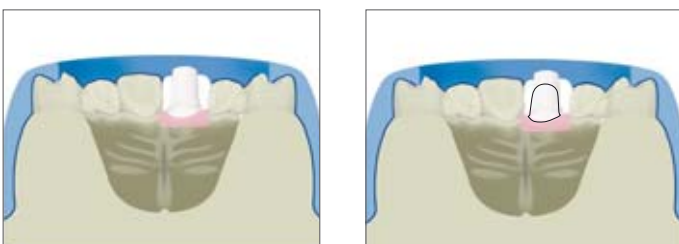

### PROCESSING THE ZIRCONIUM OXIDE SLEEVE

For individual processing, the zirconium oxide sleeve can be placed on a special holder (collect) for grinding (PEEK). The holder is available in two diameters for the implant diameters 3.3/3.8/4.3 mm and 5.0/6.0 mm respectively. The holder (collect) can be loaded into the universal holder for better handling. The holder is fixed by tightening the clamping screw (hex) in the universal holder.



Collect for zirconium oxide sleeve (PEEK)

The zirconium oxide sleeve is placed on the holder (collect) for grinding based in the diameter and turned until the antirotational mechanism engages. The zirconium oxide sleeve is fixed by tightening the clamp bolt from occlusal using a screwdriver (hex).



# CERAMIC ABUTMENT

Abrasive diamond particles are used to prepare the ceramic abutment similar to dental stump preparation. We recommend standard grit (green) and a fine grit (red) for finishing. Water cooling is absolutely required to prevent crack formations due to local overheating.

A minimum wall thickness of 1.0 mm may not be exceeded. The preparation should be carried out with a preparation angle of approx. 3° and a step width of 0.5 mm.



## IMPORTANT NOTE

If the zirconium oxide sleeve is veneered directly with ceramic, only use suitable ceramic materials with an appropriate heat expansion coefficient. Please observe the manufacturer's operating instructions. The heat expansion coefficient of the zirconium oxide sleeve is 10.5–11.0  $\mu\text{m}/\text{m}\cdot^\circ\text{C}$ .

## BONDING THE ZIRCONIUM OXIDE SLEEVE TO THE TITANIUM BASE

The bonding surface of the titanium base is blasted with 50  $\mu\text{m}$  aluminum oxide at max. 2.0 bar. Then ablate the bonding surfaces or clean with alcohol (bonding surfaces must be free of dust and grease).

**TIP:** For blasting and bonding, it is recommended that the titanium base be attached to a lab analog to protect the implant shoulder support and for easier handling. To prevent the seepage of bonding material, the hex head of the lab screw should be covered with an easily removable material (e.g. wax).



“PANAVIA™ F 2.0” bonding material is used to bind the components. The bonding material is mixed according to manufacturer's instructions and applied to the titanium base. The individualized zirconium oxide sleeve is mounted and turned until the antirotational mechanism engages. Then press the sleeve onto the titanium base as far as it will go. Excess bonding material must be removed immediately.

## IMPORTANT NOTE

The zirconium oxide sleeve and titanium base must be bonded with «PANAVIA™ F 2.0» bonding material ([www.kuraray-dental.eu](http://www.kuraray-dental.eu)). Only this bonding material is suitable for the bonding components.



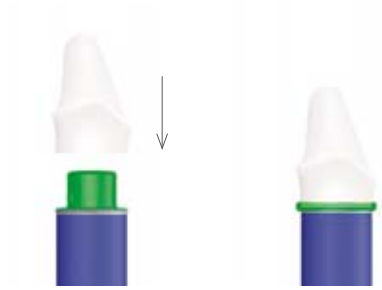

You may choose between light curing or chemical curing. Applying the oxygen blocker "OXYGUARD" ([www.kuraray-dental.eu](http://www.kuraray-dental.eu)) to the titanium/ceramic contact surface prevents oxygen exposure. Observe the manufacturer's instructions.







After curing, a rubber polisher can be used to remove the overages.





The ceramic abutment can be set in the implant and finally provided with the superstructure (all-ceramic crown, telescopic crown structure).

# ACCESSORIES AND PROSTHETIC INSTRUMENTS



## LAB ANALOGS FOR CAST FABRICATION

Art. No.	J3010.3300	J3010.3800	J3010.4300	J3010.5000	J3010.6000
					
Ø mm	3.3	3.8	4.3	5.0	6.0



## LAB SCREWS, HEX, FOR SECURING THE ABUTMENT TO THE CAST

Art. No.	Article
J4006.1601	 Lab screw, hex, brown anodized, thread M 1.6, for implant diameters 3.3/3.8/4.3 mm
J4006.2001	 Lab screw hex, brown anodized, thread M 2.0, for implant diameters 5.0/6.0 mm





## SCREWDRIVER, HEX, FOR LAB SCREW

Art. No.	Article
J5315.0510	 Screwdriver, hex, extra short
J5315.0501	 Screwdriver, hex, short
J5315.0502	 Screwdriver, hex, long



## UNIVERSAL HOLDER

Art. No.	Article
J3709.0010	 Universal holder, incl. 2 lab screws (thread M 1.6 and M 2.0) and each 1 abutment collect for implant diameters 3.3/3.8/4.3/5.0/6.0 mm
J3709.0015	 Universal holder





## ABUTMENT COLLECTS FOR UNIVERSAL HOLDER

Art. No.	J3709.3300	J3709.3800	J3709.4300	J3709.5000	J3709.6000
					
Ø mm	3.3	3.8	4.3	5.0	6.0

## HOLDER (COLLECT) FOR GRINDING THE ZIRCONIUM OXIDE SLEEVE (PEEK) FOR UNIVERSAL HOLDER

Art. No.	Article
J3712.4300	 Collect for zirconium oxide sleeve (PEEK), for implant diameters 3.3/3.8/4.3 mm
J3712.6000	 Collect for zirconium oxide sleeve (PEEK), for implant diameters 5.0/6.0 mm

## PLASTER REAMER FOR UNIVERSAL HOLDER, incl. color-coded guide pin

Art. No.	J3706.3300	J3706.3800	J3706.4300	J3706.5000	J3706.6000
					
Ø mm	3.3	3.8	4.3	5.0	6.0

# MATERIALS

<b>TITANIUM GRADE 4</b>	<b>PROPERTIES:</b>		
	Chemical structure (in %):	O	0.4 max.
		Fe	0.3 max.
		C	0.1 max.
		N	0.05 max.
		H	0.0125 max.
		Ti	> 99.0
	Mechanical properties:	Tensile strength	680 MPa min.
		Elongation	10 %
	<b>TITANIUM ALLOY Ti6Al4V</b>	<b>PROPERTIES:</b>	
Chemical structure (in %):		Al	5.5–6.75 max.
		V	3.5–4.5 max.
		Fe	0.3 max.
		C	0.08 max.
		N	0.05 max.
		H	0.015 max.
Ti		~ 90	
Mechanical properties:		Tensile strength	860 MPa min.
		Elongation	10 %
<b>CAST-ON GOLD ALLOY GOLD-PLASTIC ABUTMENT</b>	<b>PROPERTIES:</b>		
	Chemical structure (in %):	Au	60
		Pd	20
		Pt	19
		Ir	1
	Physical properties	Melting range	1400–1490 °C
		Density	17.5 g/cm <sup>3</sup>
		E-Modul	136 GPa
		Heat expansion coefficient (20–500°C)	11.9 µm/m·°C
		Heat expansion coefficient (20–600°C)	12.2 µm/m·°C
Color		white	
Mechanical properties:		drawn	
	Hardness HV5	> 215	
	Tensile strength (Rm)	> 750 MPa	
	0.2% Elongation limit (Rp 0.2%)	> 650 MPa	
	Elongation at break	> 2 %	

# MATERIALS

<b>ZIRCONIUM OXIDE</b>	<b>PROPERTIES:</b>		
Chemical structure (in %):	ZrO <sub>2</sub> + HfO <sub>2</sub> + Y <sub>2</sub> O <sub>3</sub>	> 99.0	
	Y <sub>2</sub> O <sub>2</sub>	4.5–5.4	
	HfO <sub>2</sub>	< 5	
	Al <sub>2</sub> O <sub>3</sub>	< 0.5	
	other oxides	< 0.5	
	Mechanical properties:	Density	> 6.0 g/cm <sup>3</sup>
Microstructure:	Porosity, open	0.00 %	
	Mean Linear intercept size	< 0.6 μm	
	3 pt. transversal strength	≥ 800 MPa	



# FURTHER DOCUMENTATION

Further information about CAMLOG® products is available in the following documentation:

Current CAMLOG product catalog

- Work instructions
- Preparation instructions
- Instruction manuals (included with CAMLOG® products as package inserts)
- [www.camlog.com](http://www.camlog.com)

## LOGFIT® PROSTHETIC SYSTEM FOR CEMENTABLE CROWN AND BRIDGE RESTORATIONS

Further prosthetic restoration options for the CAMLOG® Implant System are possible with the Logfit® Prosthetic System. Separate work instructions are available for this system.



**TRADE NAMES AND COPYRIGHT**

Protected trade name (trademarks) are not specially indicated. The absence of such notes may not be interpreted to mean that a trade name is unregistered. This document, including all its parts, is protected by copyright. Any use beyond the restricted limits of the copyright law without the agreement of CAMLOG Biotechnologies AG is not permissible and is punishable by law.



**HEADQUARTERS**

CAMLOG Biotechnologies AG | Margarethenstrasse 38 | CH-4053 Basel  
Phone +41 61 565 41 00 | Fax +41 61 565 41 01 | info@camlog.com | www.camlog.com

Manufacturer of CAMLOG® products: ALTATEC GmbH, Maybachstraße 5, D-71299 Wimsheim

